

---

---

**Straight cylindrical involute splines —  
Metric module, side fit —**

**Part 1:  
Generalities**

*Cannelures cylindriques droites à flancs en développante — Module  
métrique, à centrage sur flancs —*

*Partie 1: Généralités*



**PDF disclaimer**

This PDF file may contain embedded typefaces. In accordance with Adobe's licensing policy, this file may be printed or viewed but shall not be edited unless the typefaces which are embedded are licensed to and installed on the computer performing the editing. In downloading this file, parties accept therein the responsibility of not infringing Adobe's licensing policy. The ISO Central Secretariat accepts no liability in this area.

Adobe is a trademark of Adobe Systems Incorporated.

Details of the software products used to create this PDF file can be found in the General Info relative to the file; the PDF-creation parameters were optimized for printing. Every care has been taken to ensure that the file is suitable for use by ISO member bodies. In the unlikely event that a problem relating to it is found, please inform the Central Secretariat at the address given below.

© ISO 2005

All rights reserved. Unless otherwise specified, no part of this publication may be reproduced or utilized in any form or by any means, electronic or mechanical, including photocopying and microfilm, without permission in writing from either ISO at the address below or ISO's member body in the country of the requester.

ISO copyright office  
Case postale 56 • CH-1211 Geneva 20  
Tel. + 41 22 749 01 11  
Fax + 41 22 749 09 47  
E-mail [copyright@iso.org](mailto:copyright@iso.org)  
Web [www.iso.org](http://www.iso.org)

Published in Switzerland

# Contents

Page

Foreword.....	iv
Introduction .....	v
<b>1 Scope .....</b>	<b>1</b>
<b>2 Normative references .....</b>	<b>1</b>
<b>3 Terms and definitions .....</b>	<b>1</b>
<b>4 Symbols, subscripts and abbreviated terms .....</b>	<b>7</b>
4.1 General symbols .....	7
4.2 Subscripts .....	9
4.3 Formulae for dimensions and tolerances for all fit classes .....	9
<b>5 Concept of side fit splines .....</b>	<b>12</b>
<b>6 Effective fit concept.....</b>	<b>14</b>
<b>7 Basic rack profiles for spline.....</b>	<b>22</b>
<b>8 Spline fit classes.....</b>	<b>24</b>
<b>9 Space width and tooth thickness tolerances.....</b>	<b>26</b>
9.1 Total tolerance $T + \lambda$ .....	26
9.2 Deviation allowance, $\lambda$ .....	27
9.3 Total pitch deviation, $F_p$ .....	27
9.4 Total profile deviation, $F_{\alpha}$ .....	28
9.5 Total helix deviation, $F_{\beta}$ .....	29
9.6 Machining tolerance, $T$ .....	29
9.7 Effective clearance tolerance, $T_v$ .....	30
9.8 Use of effective and actual dimensions for space width and tooth thickness .....	30
<b>10 Minor and major diameters.....</b>	<b>31</b>
10.1 Tolerances .....	31
10.2 Adjustment to minor diameters ( $D_{ie}$ ), form diameters ( $D_{Fe}$ ) and major diameters ( $D_{ee}$ ) of external splines.....	32
<b>11 Manufacturing and design considerations .....</b>	<b>32</b>
11.1 Radii .....	32
11.2 Profile shifts .....	32
11.3 Eccentricity and misalignment.....	33
<b>12 Spline data.....</b>	<b>34</b>
12.1 Basic dimensions .....	34
12.2 Combination of types .....	34
12.3 Designation .....	34
12.4 Drawing data .....	35
<b>Annex A (informative) Drawing data example calculations .....</b>	<b>40</b>
<b>Bibliography .....</b>	<b>59</b>

## Foreword

ISO (the International Organization for Standardization) is a worldwide federation of national standards bodies (ISO member bodies). The work of preparing International Standards is normally carried out through ISO technical committees. Each member body interested in a subject for which a technical committee has been established has the right to be represented on that committee. International organizations, governmental and non-governmental, in liaison with ISO, also take part in the work. ISO collaborates closely with the International Electrotechnical Commission (IEC) on all matters of electrotechnical standardization.

International Standards are drafted in accordance with the rules given in the ISO/IEC Directives, Part 2.

The main task of technical committees is to prepare International Standards. Draft International Standards adopted by the technical committees are circulated to the member bodies for voting. Publication as an International Standard requires approval by at least 75 % of the member bodies casting a vote.

Attention is drawn to the possibility that some of the elements of this document may be the subject of patent rights. ISO shall not be held responsible for identifying any or all such patent rights.

ISO 4156-1 was prepared by Technical Committee ISO/TC 14, *Shafts for machinery and accessories*.

This first edition of ISO 4156-1, together with ISO 4156-2 and ISO 4156-3, cancels and replaces ISO 4156:1981 and ISO 4156:1981/Amd 1:1992, of which it constitutes a technical revision. The values and tables are the same as in ISO 4156:1981; however, some explanations and definitions have been clarified.

ISO 4156 consists of the following parts, under the general title *Straight cylindrical involute splines — Metric module, side fit*:

- *Part 1: Generalities*
- *Part 2: Dimensions*
- *Part 3: Inspection*

## Introduction

ISO 4156 provides the data and indications necessary for the design, manufacture and inspection of straight (non-helical) side-fitting cylindrical involute splines.

Straight cylindrical involute splines manufactured in accordance with ISO 4156 are used for clearance, sliding and interference connections of shafts and hubs. They contain all the necessary characteristics for the assembly, transmission of torque, and economic production.

The nominal pressure angles are  $30^\circ$ ,  $37,5^\circ$  and  $45^\circ$ . For electronic data processing purposes, the form of expression  $37,5^\circ$  has been adopted instead of  $37^\circ 30'$ . ISO 4156 establishes a specification based on the following modules:

— for pressure angles of  $30^\circ$  and  $37,5^\circ$  the module increments are

0,5; 0,75; 1; 1,25; 1,5; 1,75; 2; 2,5; 3; 4; 5; 6; 8; 10

— for pressure angle of  $45^\circ$  the module increments are

0,25; 0,5; 0,75; 1; 1,25; 1,5; 1,75; 2; 2,5



# Straight cylindrical involute splines — Metric module, side fit —

## Part 1: Generalities

### 1 Scope

This part of ISO 4156 provides the data and indications necessary for the design and manufacture of straight (non-helical) side-fitting cylindrical involute splines.

Limiting dimensions, tolerances, manufacturing errors and their effects on the fit between connecting coaxial spline elements are defined in the equations and given in the tables. Unless otherwise specified, linear dimensions are expressed in millimetres and angular dimensions in degrees.

### 2 Normative references

The following referenced documents are indispensable for the application of this document. For dated references, only the edition cited applies. For undated references, the latest edition of the referenced document (including any amendments) applies.

ISO 286-1, *ISO system of limits and fits — Part 1: Bases of tolerances, deviations and fits*

ISO 1101, *Geometrical Product Specifications (GPS) — Geometrical tolerancing — Tolerances of form, orientation, location and run-out*

ISO 4156-2, *Straight cylindrical involute splines — Metric module, side fit — Part 2: Dimensions*

ISO 4156-3:2005, *Straight cylindrical involute splines — Metric module, side fit — Part 3: Inspection*

### 3 Terms and definitions

For the purposes of this document, the following terms and definitions apply.

#### 3.1

##### **spline joint**

connecting, coaxial elements that transmit torque through the simultaneous engagement of equally spaced teeth situated around the periphery of a cylindrical external member with similar spaced mating spaces situated around the inner surface of the related cylindrical internal member

#### 3.2

##### **involute spline**

member of spline joint having teeth or spaces that have involute flank profiles

#### 3.3

##### **internal spline**

spline formed on the inner surface of a cylinder

**3.4**

**external spline**

spline formed on the outer surface of a cylinder

**3.5**

**fillet**

concave surface of the tooth or space connecting the involute flank and the root circle.

NOTE This curved surface as generated varies and cannot be properly specified by a radius of any given value.

**3.6**

**fillet root spline**

spline having a tooth or space profile in which the opposing involute flanks are connected to the root circle ( $D_{ei}$  or  $D_{ie}$  diameter) by a single fillet.

**3.7**

**flat root spline**

spline having a tooth or space profile in which each of the opposing involute flanks are connected to the root circle ( $D_{ei}$  or  $D_{ie}$  diameter) by a fillet

**3.8**

**module**

$m$

ratio of the circular pitch, expressed in millimetres, to the number  $\pi$  (or the ratio of the pitch diameter expressed in millimetres, to the number of teeth)

**3.9**

**pitch circle**

reference circle from which all normal spline dimensions are derived, and the circle on which the specified pressure angle has its nominal value

**3.10**

**pitch diameter**

$D$

diameter of the pitch circle, in millimetres, equal to the number of teeth multiplied by the module

**3.11**

**pitch point**

intersection of the spline tooth profile with the pitch circle

**3.12**

**circular pitch**

$p$

length of arc of the pitch circle between two consecutive pitch points of left- (or right-) hand flanks, which has a value of the number  $\pi$  multiplied by the module

**3.13**

**pressure angle**

$\alpha$

acute angle between a radial line passing through any point on a tooth flank and the tangent plane to the flank at that point

**3.14**

**standard pressure angle**

$\alpha_D$

pressure angle at the specified pitch point

**3.15****base circle**

circle from which Involute spline tooth profiles are generated

**3.16****base diameter**

$D_b$

diameter of the base circle

**3.17****base pitch**

$p_b$

arc length of the base circle between two consecutive corresponding flanks

**3.18****major circle**

outermost (largest) circle of the external or internal spline

**3.19****major diameter**

$D_{ee}, D_{ei}$

diameter of the major circle

**3.20****minor circle**

innermost (smallest) circle of the external or internal spline

**3.21****minor diameter,  $D_{ie}, D_{ii}$** 

diameter of the minor circle

**3.22****form circle**

circle used to define the depth of involute profile control

NOTE In the case of an external spline it is located near and above the minor diameter, and on an internal spline near and below the major diameter

**3.23****form diameter**

$D_{Fe}, D_{Fi}$

diameter of the form circle

**3.24****depth of engagement**

radial distance from the minor circle of the internal spline to the major circle of the external spline, minus corner clearance and/or chamfer depth

**3.25****basic (circular) space width or tooth thickness at the pitch diameter**

$E$  or  $S$

for 30°, 37,5° and 45° pressure angle splines, half the circular pitch.

**3.26****actual space width**

practically measured circular space width, on the pitch circle, of any single space width within the limit values

$E_{max}$  and  $E_{min}$

**3.27**  
**effective space width**

$E_v$   
space width where an imaginary perfect external spline would fit without clearance or interference, given by the size of the tooth thickness of this external spline, considering engagement of the entire axial length of the splined assembly

NOTE The minimum effective space width ( $E_{v \min}$ , always equal to  $E$ ) of the internal spline is always basic, as shown in Table 3.

**3.28**  
**actual tooth thickness**

practically measured circular tooth thickness, on the pitch circle, of any single tooth within the limit values  $S_{\max}$  and  $S_{\min}$

**3.29**  
**effective tooth thickness**

$S_v$   
tooth thickness where an imaginary perfect internal spline would fit without clearance or interference, given by the size of the space width of this internal spline, considering engagement of the entire axial length of the splined assembly

**3.30**  
**effective clearance**

$c_v$   
(looseness or interference) effective space width of the internal spline minus the effective tooth thickness of the external spline

NOTE For looseness,  $c_v$  is positive; for interference,  $c_v$  is negative.

**3.31**  
**theoretical clearance**

$c$   
(looseness or interference) actual space width of the internal spline minus the actual tooth thickness of the external spline

NOTE It does not define the effective fit between internal and external spline, because of the effect of deviations.

**3.32**  
**form clearance**

$c_F$   
radial clearance between the form diameter of the internal spline and the major diameter of the external spline, or between the minor diameter of the internal spline and the form diameter of the external spline

NOTE It allows eccentricity of their respective pitch circles.

**3.33**  
**total pitch deviation**

$F_p$   
absolute value of the difference between the greatest positive and negative deviations from the theoretical spacing

**3.34**  
**total profile deviation**

$F_\alpha$   
absolute value of the difference between the greatest positive and negative deviations from the theoretical tooth profile, measured normal to the flanks

**3.35**  
**total helix deviation**

$F_{\beta}$

absolute value of the difference between the two extreme deviations from the theoretical direction parallel to the reference axis

NOTE This includes parallelism and alignment deviations, see Figure 1.

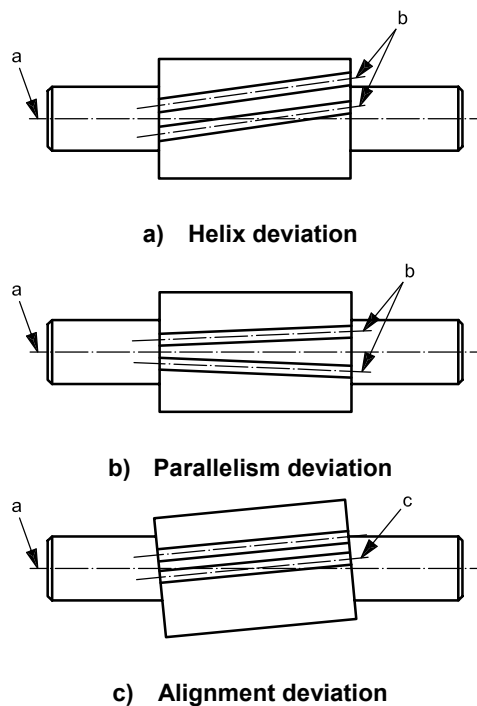

- a Reference axis.
- b Centreline of teeth.
- c Effective spline axis.

**Figure 1 — Helix deviations**

**3.36**  
**parallelism deviation**

deviation of parallelism of a single spline tooth to any other single spline tooth

See Figure 1 b).

**3.37**  
**alignment deviation**

deviation of the effective spline axis with respect to the reference axis

See Figure 1 c).

**3.38**  
**out-of-roundness**

deviation of the spline from a true circular configuration

**3.39**  
**effective deviation**

accumulated effect of the spline deviations on the fit with the mating part

**3.40**  
**deviation allowance**

$\lambda$

permissible deviation between minimum actual and minimum effective space width or maximum effective and maximum actual tooth thickness

**3.41**  
**machining tolerance**

$T$

permissible deviation between maximum actual and minimum actual space width or tooth thickness

**3.42**  
**effective clearance tolerance**

$T_v$

permissible deviation between maximum effective and minimum effective space width or tooth thickness

**3.43**  
**total tolerance**

$T + \lambda$

machining tolerance plus the deviation allowance

**3.43.1**  
**total tolerance**

⟨internal spline⟩ difference between the minimum effective space width and the maximum actual space width

**3.43.2**  
**total tolerance**

⟨external spline⟩ difference between the maximum effective tooth thickness and the minimum actual tooth thickness

**3.44**  
**basic dimension**

numerical value to describe the theoretically exact size, shape or location of a feature

NOTE It is the basis from which permissible deviations are established by tolerances.

**3.45**  
**auxiliary dimension**

dimension, without tolerance, given for information purposes only, for the determination of the useful production and control dimensions.

## 4 Symbols, subscripts and abbreviated terms

### 4.1 General symbols

The general symbols used to designate the various spline terms and dimensions are given below.

$D$	Pitch diameter	mm
$D_{Fe}$	Form diameter, external spline	mm
$D_{Fe\ max}$	Maximum form diameter, external spline	mm
$D_{Fi}$	Form diameter, internal spline	mm
$D_{Fi\ min}$	Minimum form diameter, internal spline	mm
$D_{Re}$	Diameter of measuring ball or pin for external spline	mm
$D_{Ri}$	Diameter of measuring ball or pin for internal spline	mm
$D_b$	Base diameter	mm
$D_{ee}$	Major diameter, external spline	mm
$D_{ee\ max}$	Maximum major diameter, external spline	mm
$D_{ee\ min}$	Minimum major diameter, external spline	mm
$D_{ei}$	Major diameter, internal spline	mm
$D_{ei\ max}$	Maximum major diameter, internal spline	mm
$D_{ei\ min}$	Minimum major diameter, internal spline	mm
$D_{ie}$	Minor diameter, external spline	mm
$D_{ie\ max}$	Maximum minor diameter, external spline	mm
$D_{ie\ min}$	Minimum minor diameter, external spline	mm
$D_{ii}$	Minor diameter, internal spline	mm
$D_{ii\ max}$	Maximum minor diameter, internal spline	mm
$D_{ii\ min}$	Minimum minor diameter, internal spline	mm
$E$	Basic space width, circular	mm
$E_{max}$	Maximum actual space width	mm
$E_{min}$	Minimum actual space width	mm
$E_v$	Effective space width, circular	mm
$E_{v\ max}$	Maximum effective space width	mm
$E_{v\ min}$	Minimum effective space width	mm
$F_p$	Total cumulative pitch deviation	$\mu\text{m}$
$F_\alpha$	Total profile deviation	$\mu\text{m}$
$F_\beta$	Total helix deviation	$\mu\text{m}$
$K_e$	Approximation factor for external spline	—
$K_i$	Approximation factor for internal spline	—
$M_{Re}$	Measurement over two balls or pins, external splines	mm
$M_{Ri}$	Measurement between two balls or pins, internal	mm
$S$	Basic tooth thickness, circular	mm

$S_{\max}$	Maximum actual tooth thickness	mm
$S_{\min}$	Minimum actual tooth thickness	mm
$S_v$	Effective tooth thickness, circular	mm
$S_{v \max}$	Maximum effective tooth thickness	mm
$S_{v \min}$	Minimum effective tooth thickness	mm
$T$	Machining tolerance	$\mu\text{m}$
$T_v$	Effective clearance tolerance	$\mu\text{m}$
$W$	Measurement over $k$ teeth, external spline	mm
$b$	Spline length	mm
$c_F$	Form clearance	mm
$c_v$	Effective clearance (looseness or interference)	$\mu\text{m}$
$c_{v \max}$	Maximum effective clearance	$\mu\text{m}$
$c_{v \min}$	Minimum effective clearance	$\mu\text{m}$
$d_{ce}$	Ball or pin contact diameter, external spline	mm
$d_{ci}$	Ball or pin contact diameter, internal spline	mm
$es_v$	Fundamental deviation, external	$\mu\text{m}$
$h_s$	Form tooth height	mm
$\text{inv } \alpha$	Involute $\alpha$ ( $= \tan \alpha - \pi \cdot \alpha / 180^\circ$ )	—
$k$	Number of measured teeth	—
$m$	Module	mm
$p$	Circular pitch	mm
$p_b$	Base pitch	mm
$z$	Number of teeth	—
$\alpha$	Pressure angle	$^\circ$
$\alpha_{Fe}$	Pressure angle at form diameter, external spline	$^\circ$
$\alpha_{Fi}$	Pressure angle at form diameter, internal spline	$^\circ$
$\alpha_{ce}$	Pressure angle at ball or pin diameter, external spline	$^\circ$
$\alpha_{ci}$	Pressure angle at ball or pin diameter, internal spline	$^\circ$
$\alpha_D$	Standard pressure angle at pitch diameter	$^\circ$
$\alpha_e$	Pressure angle at ball or pin centre, external spline	$^\circ$
$\alpha_i$	Pressure angle at ball or pin centre, internal spline	$^\circ$
$\lambda$	Deviation allowance	$\mu\text{m}$
$\rho_{Fa}$	Fillet radius of the basic rack, external spline	mm
$\rho_{Fi}$	Fillet radius of the basic rack, internal spline	mm
$k; js; h; f; e; d$	Fundamental deviation of the external spline	$\mu\text{m}$

## 4.2 Subscripts

The following subscripts are used as part of the above general symbols to designate relative conditions or locations:

- i minor or internal (in the last case in the last position)
- e major or external (in the last case in the last position)
- b at the base
- c at contact point
- d tolerance based on pitch diameter ( $D$ )
- E tolerance based on space width ( $E$ ) or tooth thickness ( $S$ )
- F pertaining to form diameter
- v effective
- R pertaining to gauges
- D standard

NOTE In electronic data processing (EDP), it is not always possible to present symbols in their theoretically correct form because of limitations of connected printing equipment. For this reason, some alternative symbols for EDP usage are given in Table 1 (for example, the symbol for  $D_b$  for base diameter may be printed as DB).

## 4.3 Formulae for dimensions and tolerances for all fit classes

The formulae for dimensions and tolerances for all fit classes are given in Table 1.

Table 1 — Formulae for dimensions and tolerances for all fit classes

Term	Symbol	Formula	EDP representation
Pitch diameter	$D$	$m \cdot z$	D
Base diameter	$D_b$	$m \cdot z \cdot \cos \alpha_D$	DB
Circular pitch	$p$	$m \cdot \pi$	P
Base pitch	$p_b$	$m \cdot \pi \cdot \cos \alpha_D$	PB
Fundamental deviation, external	$es_v$	Resulting from fundamental deviation k, js, h, f, e and d	ESV
Minimum major diameter, internal: 30°, flat root 30°, fillet root 37,5°, fillet root 45°, fillet root	$D_{ei \min}$ $D_{ei \min}$ $D_{ei \min}$ $D_{ei \min}$	$m \cdot (z + 1,5)$ $m \cdot (z + 1,8)$ $m \cdot (z + 1,4)$ $m \cdot (z + 1,2)$	DEIMIN DEIMIN DEIMIN DEIMIN
Maximum major diameter, internal	$D_{ei \max}$	$D_{ei \min} + (T + \lambda) / \tan \alpha_D$ (see Note 1)	DEIMAX
Minimum form diameter, internal: 30° flat root and fillet root 37,5° fillet root 45° fillet root	$D_{Fi \min}$ $D_{Fi \min}$ $D_{Fi \min}$	$m \cdot (z + 1) + 2 \cdot c_F$ $m \cdot (z + 0,9) + 2 \cdot c_F$ $m \cdot (z + 0,8) + 2 \cdot c_F$	DFIMIN DFIMIN DFIMIN
Minimum minor diameter, internal	$D_{ii \min}$	$D_{Fe \max} + 2 \cdot c_F$ (see Note 2)	DIIMIN
Maximum minor diameter, internal: $m \leq 0,75$ $0,75 < m < 2$ $m \geq 2$	$D_{ii \max}$ $D_{ii \max}$ $D_{ii \max}$	$D_{ii \min} + IT 10$ $D_{ii \min} + IT 11$ $D_{ii \min} + IT 12$	DIIMAX DIIMAX DIIMAX
Basic space width	$E$	$0,5 \cdot \pi \cdot m$	E
Minimum effective space width	$E_{v \min}$	$0,5 \cdot \pi \cdot m$	EVMIN
Maximum actual space width: class 4 class 5 class 6 class 7	$E_{\max}$ $E_{\max}$ $E_{\max}$ $E_{\max}$	$E_{v \min} + (T + \lambda)$ (see Note 3) $E_{v \min} + (T + \lambda)$ (see Note 3) $E_{v \min} + (T + \lambda)$ (see Note 3) $E_{v \min} + (T + \lambda)$ (see Note 3)	EMAX EMAX EMAX EMAX
Minimum actual space width	$E_{\min}$	$E_{v \min} + \lambda$	EMIN
Maximum effective space width	$E_{v \max}$	$E_{v \min} + T_v$	EVMAX
Maximum major diameter, external: 30°, flat root and fillet root 37,5°, fillet root 45°, fillet root	$D_{ee \max}$ $D_{ee \max}$ $D_{ee \max}$	$m \cdot (z + 1) + es_v / \tan \alpha_D$ (see Note 4) $m \cdot (z + 0,9) + es_v / \tan \alpha_D$ (see Note 4) $m \cdot (z + 0,8) + es_v / \tan \alpha_D$ (see Note 4)	DEEMAX DEEMAX DEEMAX
Minimum major diameter, external: $m \leq 0,75$ $0,75 < m < 2$ $m \geq 2$	$D_{ee \min}$ $D_{ee \min}$ $D_{ee \min}$	$D_{ee \max} - IT 10$ $D_{ee \max} - IT 11$ $D_{ee \max} - IT 12$	DEEMIN DEEMIN DEEMIN

Table 1 (continued)

Term	Symbol	Formula	EDP representation
Maximum form diameter (see Note 5)	$D_{Fe\ max}$	$2 \times \sqrt{(0,5D_b)^2 + \left(0,5D \times \sin \alpha_D - \frac{h_s - \frac{0,5 \times es_v}{\tan \alpha_D}}{\sin \alpha_D}\right)^2}$	DFEMAX
Maximum minor diameter, external:			
30°, flat root	$D_{ie\ max}$	$m \cdot (z - 1,5) + es_v / \tan \alpha_D$	DIEMAX
30°, fillet root	$D_{ie\ max}$	$m \cdot (z - 1,8) + es_v / \tan \alpha_D$	DIEMAX
37,5°, fillet root	$D_{ie\ max}$	$m \cdot (z - 1,4) + es_v / \tan \alpha_D$	DIEMAX
45°, fillet root	$D_{ie\ max}$	$m \cdot (z - 1,2) + es_v / \tan \alpha_D$	DIEMAX
Minimum minor diameter, external	$D_{ie\ min}$	$D_{ie\ max} - (T + \lambda) / \tan \alpha_D$ (see Note 1)	DIEMIN
Basic tooth thickness	$S$	$0,5 \cdot \pi \cdot m$	S
Maximum effective tooth thickness	$S_{v\ max}$	$S + es_v$	SVMAX
Minimum actual tooth thickness:			
class 4	$S_{min}$	$S_{v\ max} - (T + \lambda)$ (see Note 3)	SMIN
class 5	$S_{min}$	$S_{v\ max} - (T + \lambda)$ (see Note 3)	SMIN
class 6	$S_{min}$	$S_{v\ max} - (T + \lambda)$ (see Note 3)	SMIN
class 7	$S_{min}$	$S_{v\ max} - (T + \lambda)$ (see Note 3)	SMIN
Maximum actual tooth thickness	$S_{max}$	$S_{v\ max} - \lambda$	SMAX
Minimum effective tooth thickness	$S_{v\ min}$	$S_{v\ max} - T_v$	SVMIN
Total tolerance, space width or tooth thickness	$(T + \lambda)$	(see Note 6)	TLAM
Maximum effective clearance	$c_{v\ max}$	$E_{v\ max} - S_{v\ min}$	CVMAX
Minimum effective clearance	$c_{v\ min}$	$E_{v\ min} - S_{v\ max}$	CVMIN
Form clearance	$c_F$	see Note 5	CF
Form tooth height	$h_s$	see Note 5	HS
Ball or pin diameter, internal spline	$D_{Ri}$	see Note 7	DRI
Ball or pin diameter, external spline	$D_{Re}$	see Note 7	DRE
Measurement between balls or pins	$M_{ri}$	see Note 7	MRI
Measurement over balls or pins	$M_{re}$	see Note 7	MRE
Change factor, internal	$K_i$	see Note 7	KI
Change factor, external	$K_e$	see Note 7	KE
NOTE 1 $(T + \lambda)$ for class 7 — see 9.1.			
NOTE 2 For all classes of fit, always take the $D_{Fe\ max}$ value corresponding to the H/h fit.			
NOTE 3 See Clause 8 and ISO 4156-2.			
NOTE 4 Take $es_v = 0$ for fundamental deviation js and k.			
NOTE 5 For $h_s$ , see Figure 15 et Table 2.			
NOTE 6 See 9.1.			
NOTE 7 See ISO 4156-3 concerning the choice of balls or pins.			

## 5 Concept of side fit splines

This part of ISO 4156 defines side fit involute splines with pressure angles of 30°, 37,5° and 45°. The transmission of torque is achieved by contact of the tooth flanks only. This is possible in the clockwise or anticlockwise direction of rotation (see Figure 2). The opposite tooth flanks, major and minor diameters shall have clearance.

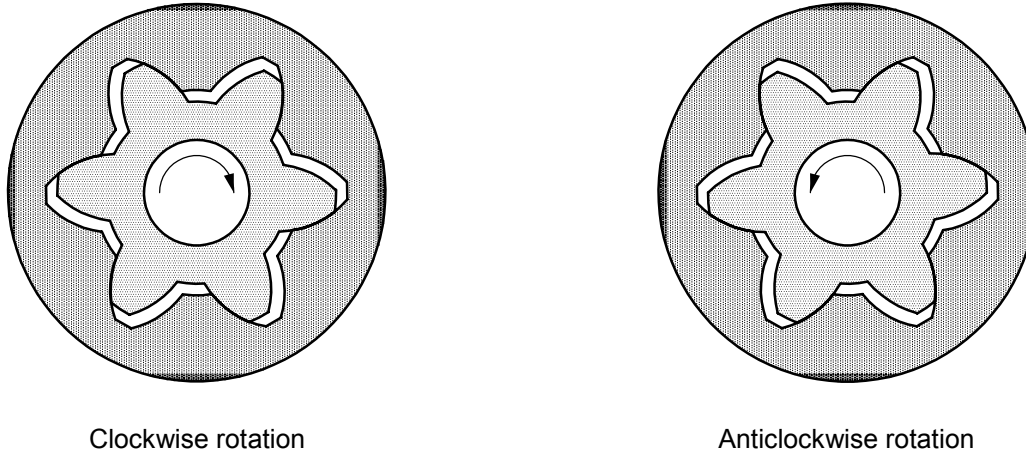
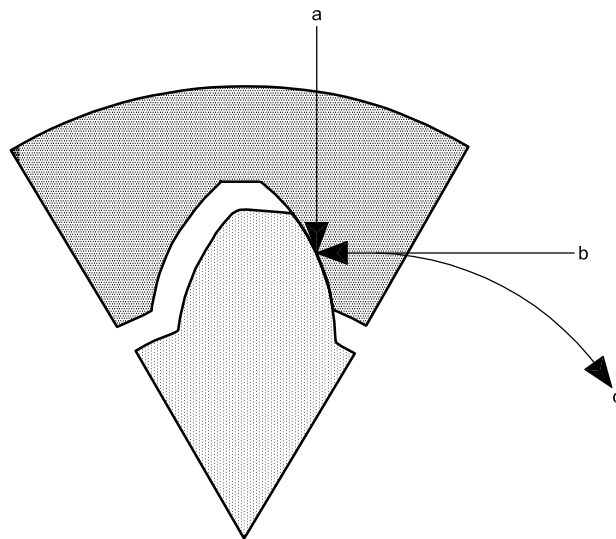

Figure 2 — Side fit tooth flank contact

The nature of the involute profile divides the torque into two directions resulting in a centring force (see Figure 3). This centring force enables side fit involute splines to be centralized by the tooth flanks.



- a Centring force.
- b Rotation force.
- c Torque.

Figure 3 — Centring force

The sizes of space width and tooth thickness (see Figure 4) are defined as the length of the arc at the theoretical pitch circle diameter.

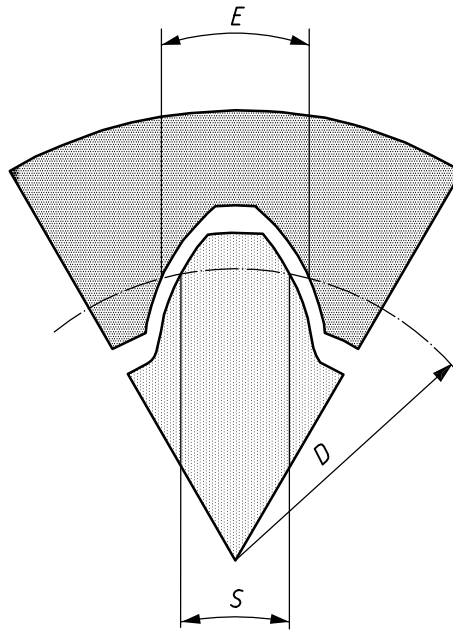

**Figure 4 — Space width and tooth thickness**

The major and minor diameters (see Figure 5) always have clearance and do not contact each other.

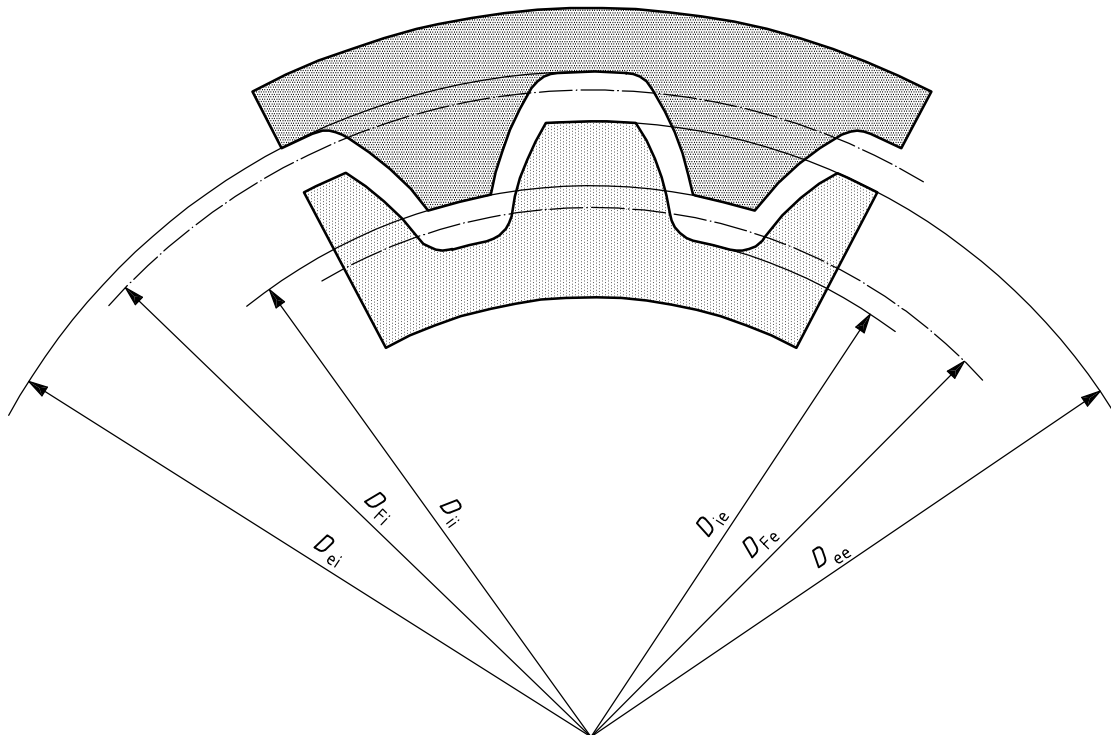

**Figure 5 — Diameters**

## 6 Effective fit concept

To be able to machine the spaces of internal splines and the teeth of external splines, a machining tolerance commonly referred to as the actual machining tolerance is necessary. Four classes of machining tolerance (classes 4, 5, 6 and 7) are provided for the different needs of industrial use. The machining tolerance,  $T$  (see Figure 6), is applied to the space width of internal splines and to the tooth thickness of external splines.

The upper machining tolerance limit is referred to as maximum actual and the lower one is referred to as minimum actual.

Similar to cylindrical fits between hubs and shafts, form deviations of the geometry (see Figure 7) affect the maximum material condition and hence the fit. The form deviation is the deviation compared to the perfect cylinder. The form deviations of splines are much more complex and occur on each flank of every space or tooth. These form deviations have an accumulative effect which is referred to as effective deviation.

The form deviations consist of three types: profile deviation, index deviation and helix deviation. The positive material elements of these deviations result in a reduction of effective space width of an internal spline, or an increase in the effective tooth thickness of an external spline, and hence a reduction in the effective clearance. This effect can only be detected by the use of an imaginary perfect mating spline that fits without looseness or interference.

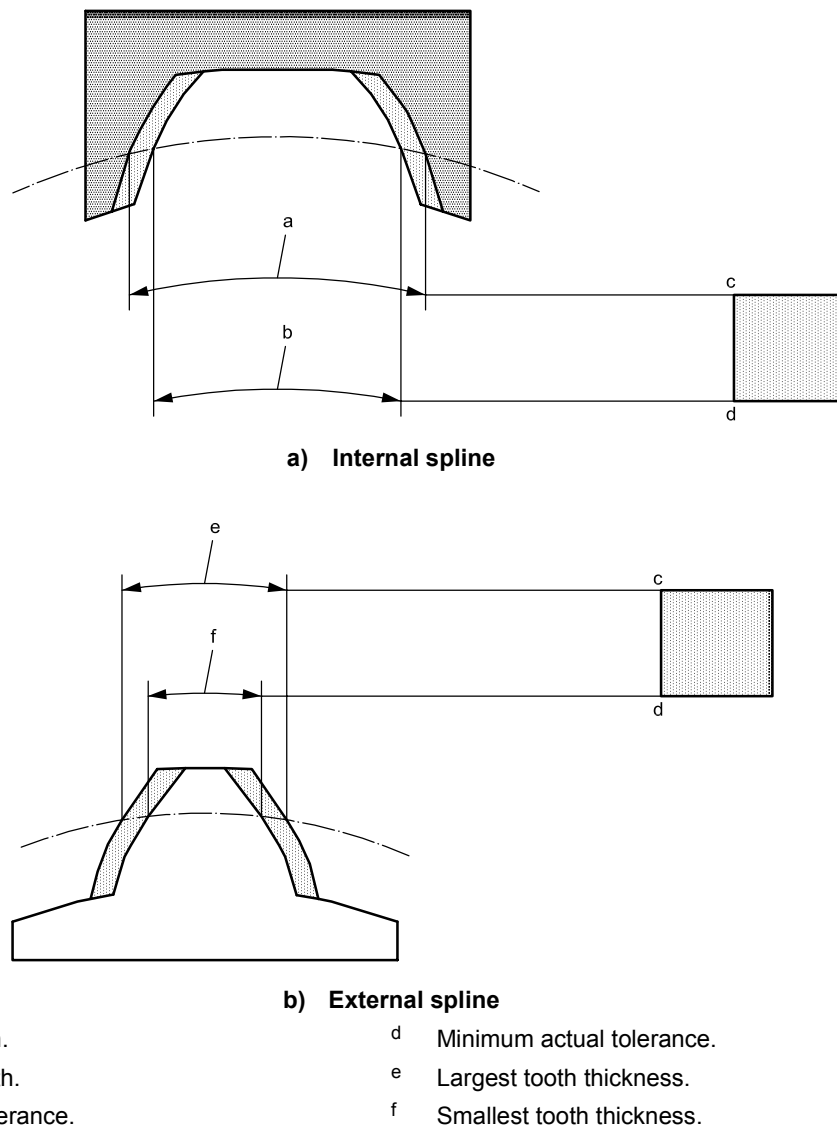

**Figure 6 — Machining tolerance,  $T$**

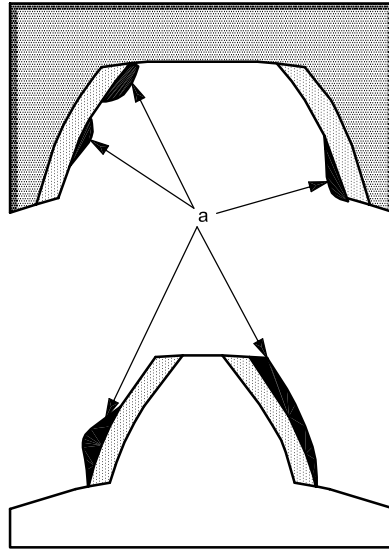

<sup>a</sup> Form deviation.

**Figure 7 — Form deviations**

The positive material elements of profile deviation (see Figure 8) will result in a smaller space or a larger tooth thickness which has an effect on the fit with a mating part.

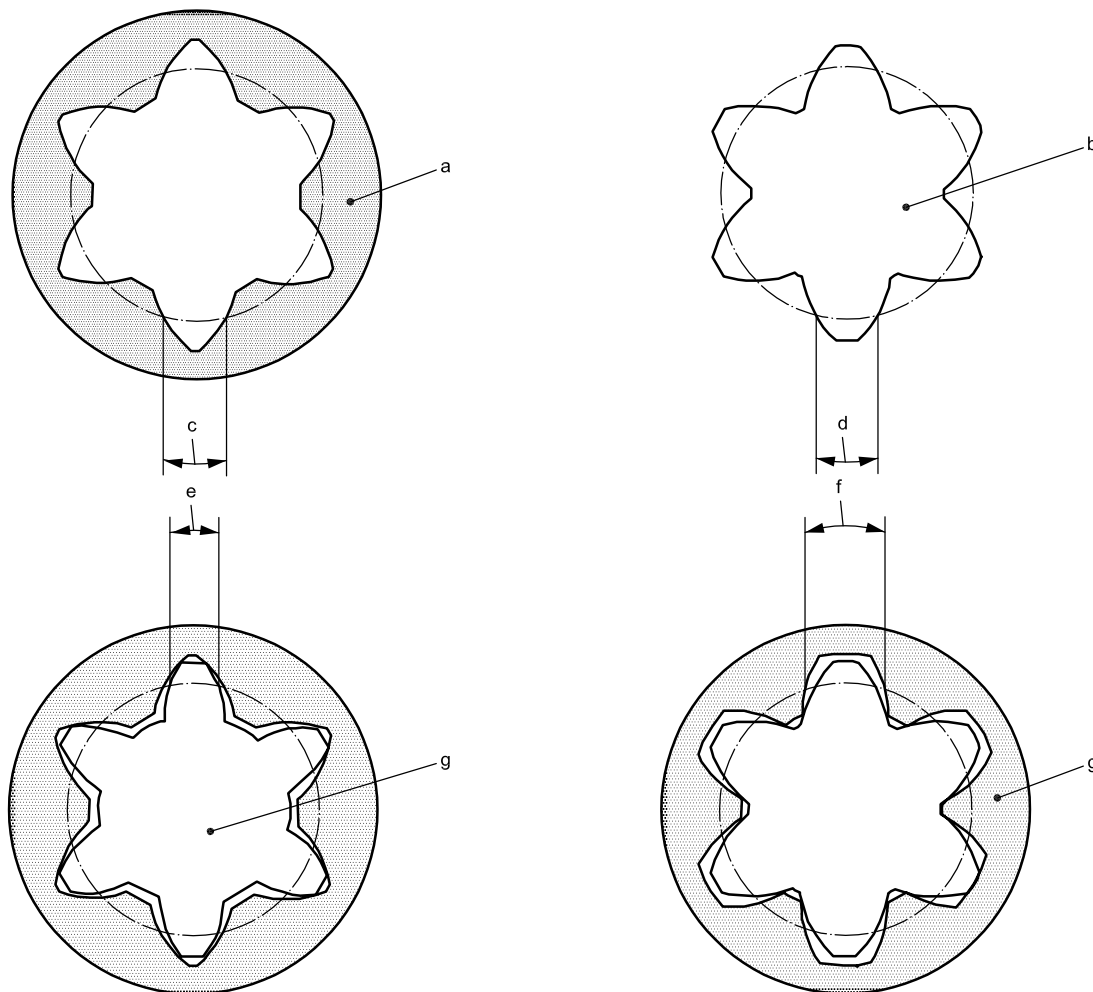

- a Internal spline.
- b External spline.
- c Space width, actual.
- d Tooth thickness, actual.
- e Space width, effective.
- f Tooth thickness, effective.
- g Mating part.

Figure 8 — Profile deviation

The positive material elements of pitch deviation (see Figure 9) will also result in a smaller space width or a larger tooth thickness which again affects the fit with a mating part.

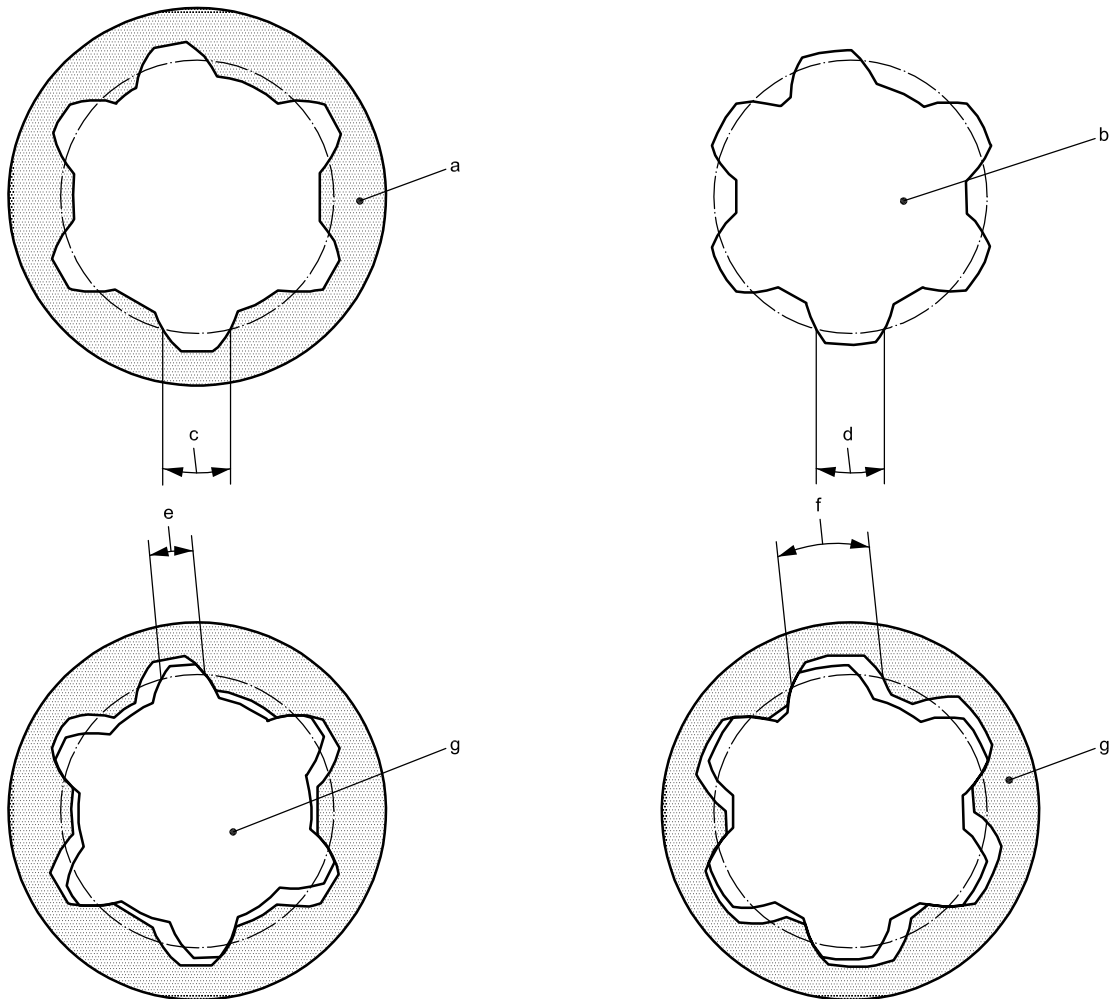

- a Internal spline.
- b External spline.
- c Space width, actual.
- d Tooth thickness, actual.
- e Space width, effective.
- f Tooth thickness, effective.
- g Mating part.

**Figure 9 — Pitch deviation**

The positive material elements of helix deviation (see Figure 10) will also result in a smaller space width or a larger tooth thickness which again affects the fit with a mating part.

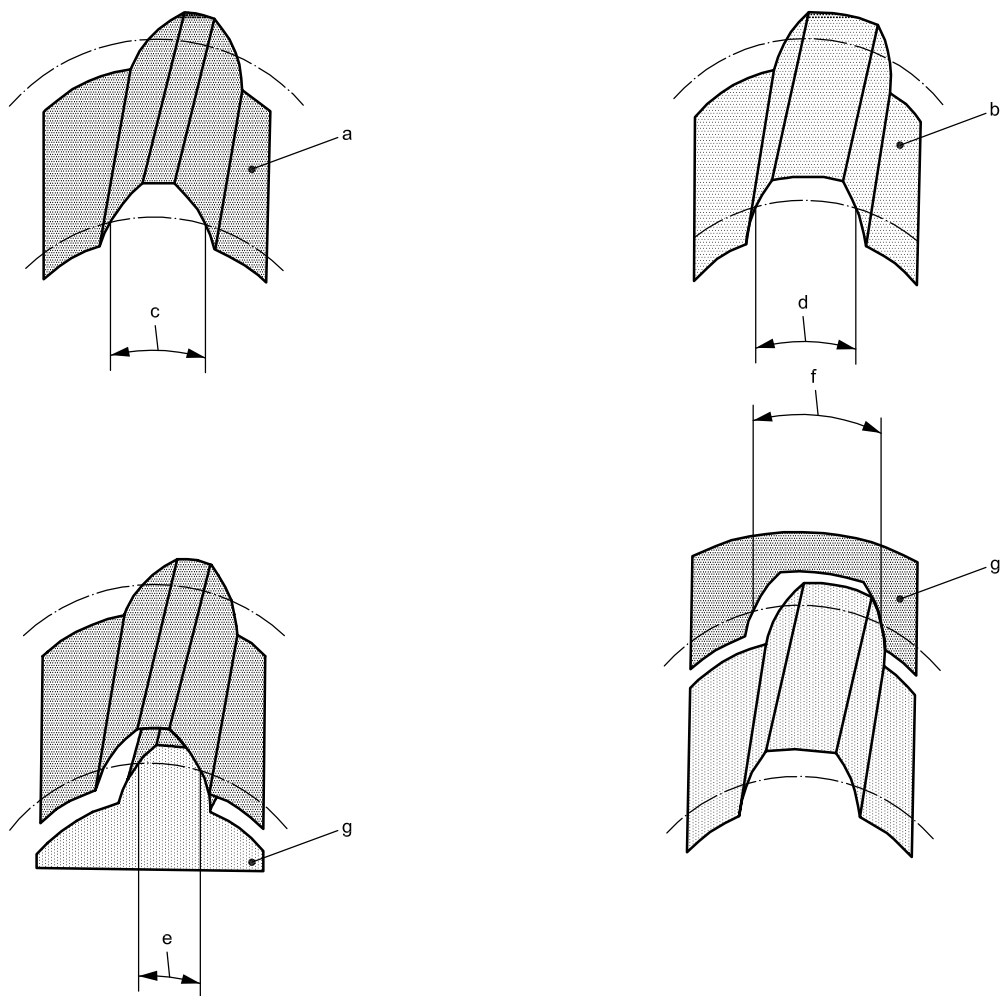

- a Internal spline.
- b External spline.
- c Space width, actual.
- d Tooth thickness, actual.
- e Space width, effective.
- f Tooth thickness, effective.
- g Mating part.

Figure 10 — Helix deviation

The accumulated form deviations (see Figure 11) of each flank result in an effective size of space width or tooth thickness.

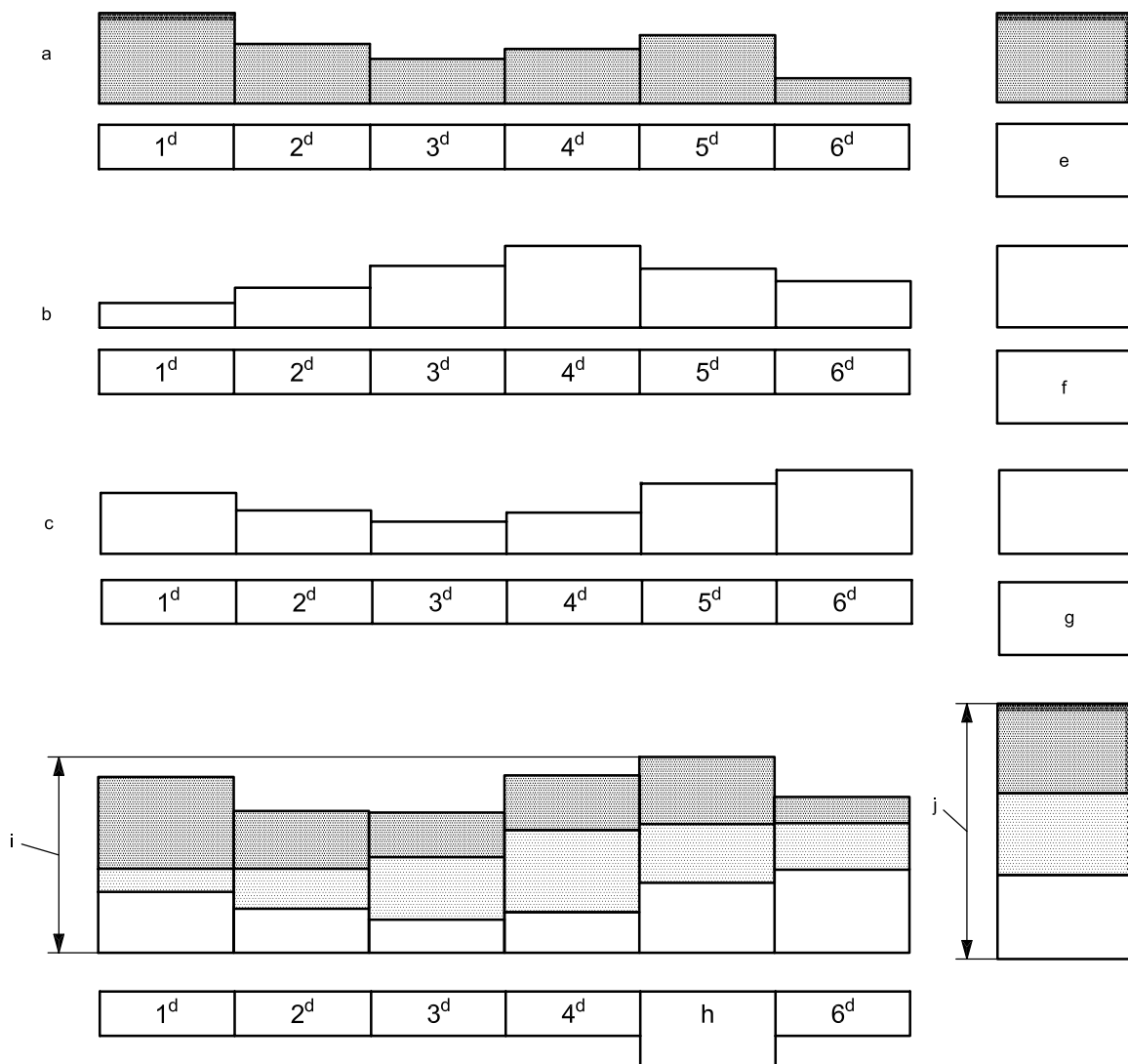

- a Profile deviation.
- b Pitch deviation.
- c Helix deviation.
- d Tooth.
- e Maximum at Tooth 1.
- f Maximum at Tooth 4.
- g Maximum at Tooth 6.
- h Maximum at Tooth 5.
- i Accumulation = effective deviation  $\lambda$ .
- j Theoretical maximum.

Figure 11 — Influence of form deviations

The true effective size of a spline part with accumulated form deviations can only be found using an imaginary perfect mating spline that fits without looseness or interference (see Figure 12).

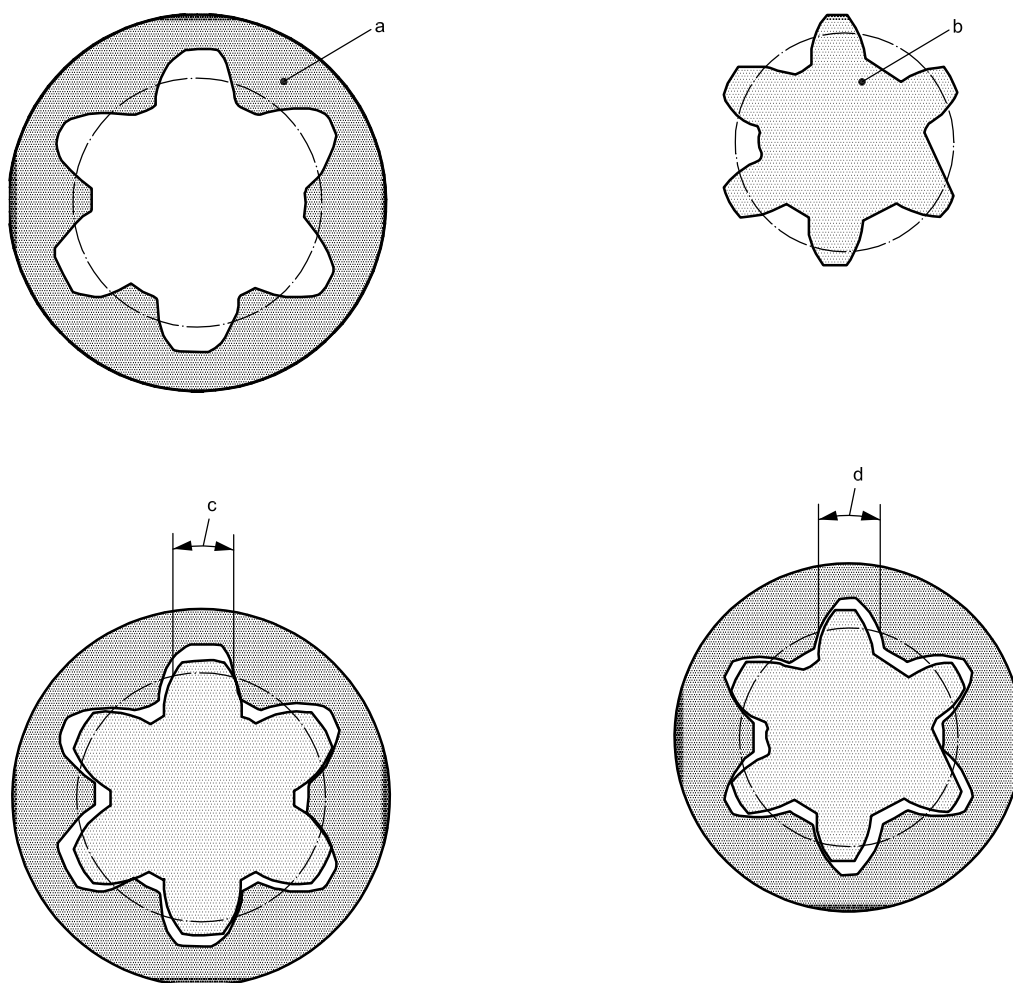

- a Internal spline with form deviations.
- b External spline with form deviations.
- c Internal effective space width.
- d External effective tooth thickness.

**Figure 12 — True effective space width and tooth thickness**

In addition to the machining tolerance and because of the form deviations, spline parts have an effective tolerance (see Figure 13). For internal parts, this creates a minimum effective tolerance limit of space width, and for external parts, a maximum effective tolerance limit of tooth thickness. See also Figure 14.

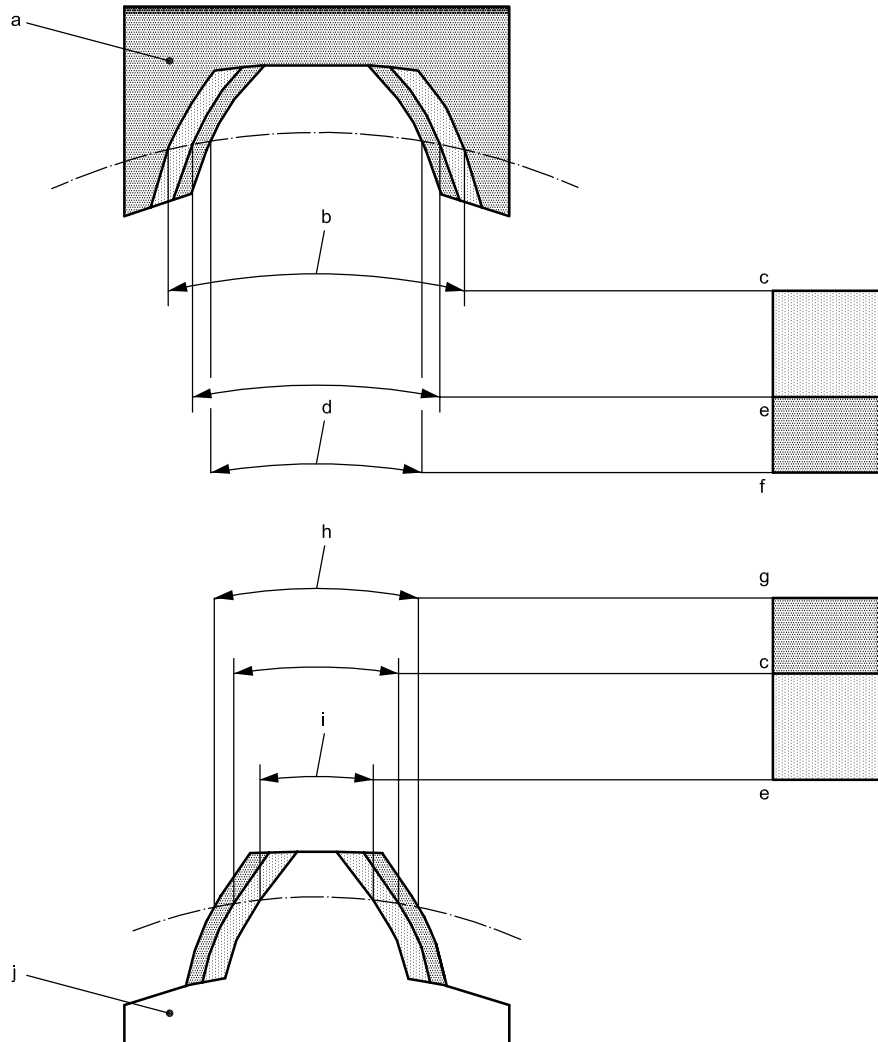

- a Internal spline.
- b Largest space width.
- c Maximum actual tolerance.
- d Smallest space width.
- e Minimum actual tolerance.
- f Minimum effective tolerance of space width.
- g Maximum effective tolerance of tooth thickness.
- h Largest tooth thickness.
- i Smallest tooth thickness.
- j External spline.

**Figure 13 — Actual and effective tolerances**

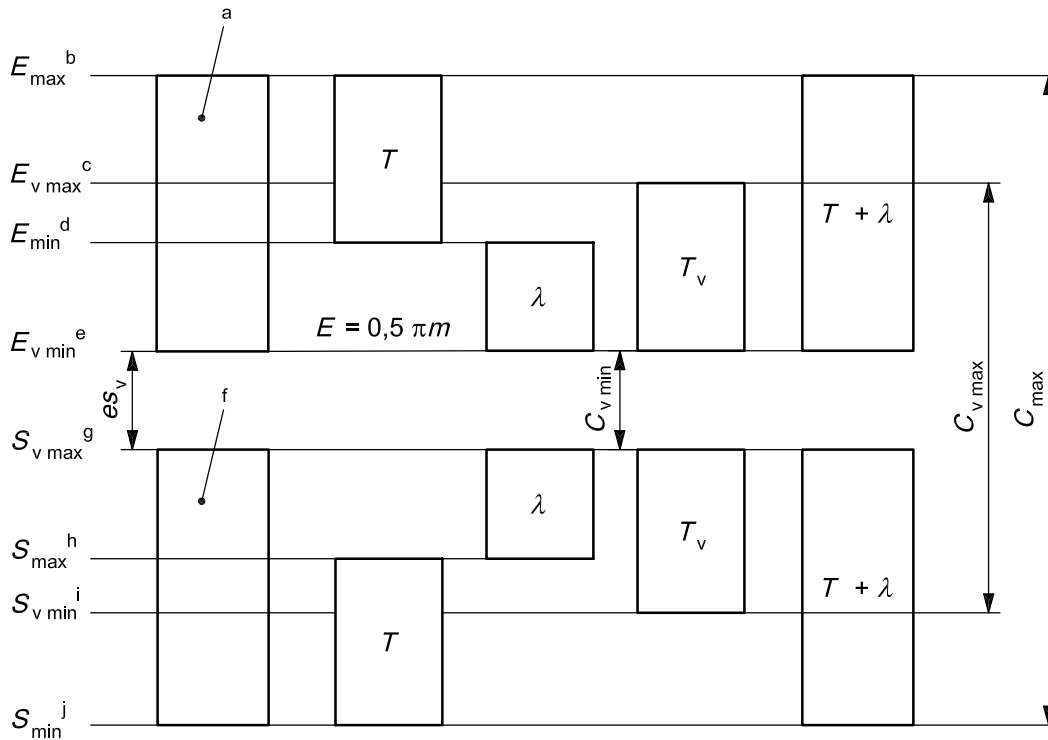

- a Space width, internal.
- b Maximum actual space width.
- c Maximum effective space width.
- d Minimum actual space width.
- e Minimum effective space width.
- f Tooth thickness, external.
- g Maximum effective tooth thickness.
- h Maximum actual tooth thickness.
- i Minimum effective tooth thickness.
- j Minimum actual tooth thickness.

Figure 14 — Graphical display of space width and tooth thickness theoretical tolerance zones

## 7 Basic rack profiles for spline

The basic rack is a section of the tooth surface on an involute spline of infinitely large diameter on a plane at right angles to the tooth surfaces, the profile of which is used as the basis for defining the standard tooth dimensions of a system of involute splines. The reference line is a straight line crossing the profile of the basic rack, with reference to which the tooth dimensions are specified. The profile of the basic rack for standard pressure angle splines is represented in Figure 15 and Table 2.

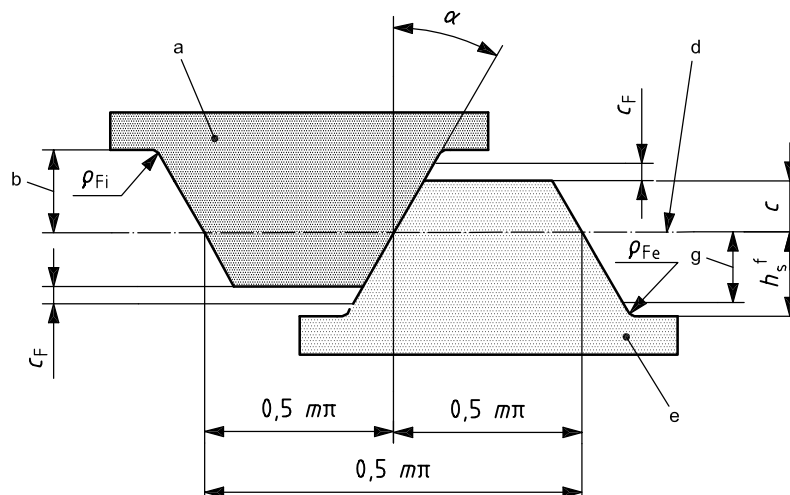

- a Internal spline.
- b Major space height.
- c Major tooth height.
- d Pitch line.
- e External spline.
- f Form tooth height.
- g Minor tooth height.

Figure 15 — Basic rack profile

Table 2 — Dimensions of basic rack

Parameter	Pressure angle			
	30°		37,5°	45°
	Flat root	Fillet root		
Major space height	0,75 <i>m</i>	0,9 <i>m</i>	0,7 <i>m</i>	0,6 <i>m</i>
Major tooth height	0,5 <i>m</i>	0,5 <i>m</i>	0,45 <i>m</i>	0,4 <i>m</i>
Form tooth height, $h_s$	0,6 <i>m</i>	0,6 <i>m</i>	0,55 <i>m</i>	0,5 <i>m</i>
Minor tooth height	0,75 <i>m</i>	0,9 <i>m</i>	0,7 <i>m</i>	0,6 <i>m</i>
Root radius, $\rho_{Fi}$	0,2 <i>m</i>	0,4 <i>m</i>	0,3 <i>m</i>	0,25 <i>m</i>
Root radius, $\rho_{Fe}$	0,2 <i>m</i>	0,4 <i>m</i>	0,3 <i>m</i>	0,25 <i>m</i>
Form clearance, $c_F$	0,1 <i>m</i>	0,1 <i>m</i>	0,1 <i>m</i>	0,1 <i>m</i>

NOTE Concerning Figure 15: For internal splines (hub), the form diameter, obtained by generating from the basic rack, is always greater than the form diameter shown in the tables of dimensions in ISO 4156-2, which correspond in all fit cases to the major maximum diameter of the shaft increased to diametrical form clearance ( $2c_F$ ). For external splines (shafts),  $c_F$  is obtained by generation from the basic rack ( $D_{Fe \max}$ ) and for H/h fit (see Note 2 to Table 1).

## 8 Spline fit classes

To achieve different amounts of clearance or interference between the space width and the tooth thickness, this part of ISO 4156 has a number of fit classes (see Figure 16). These result in different amounts of clearance or interference.

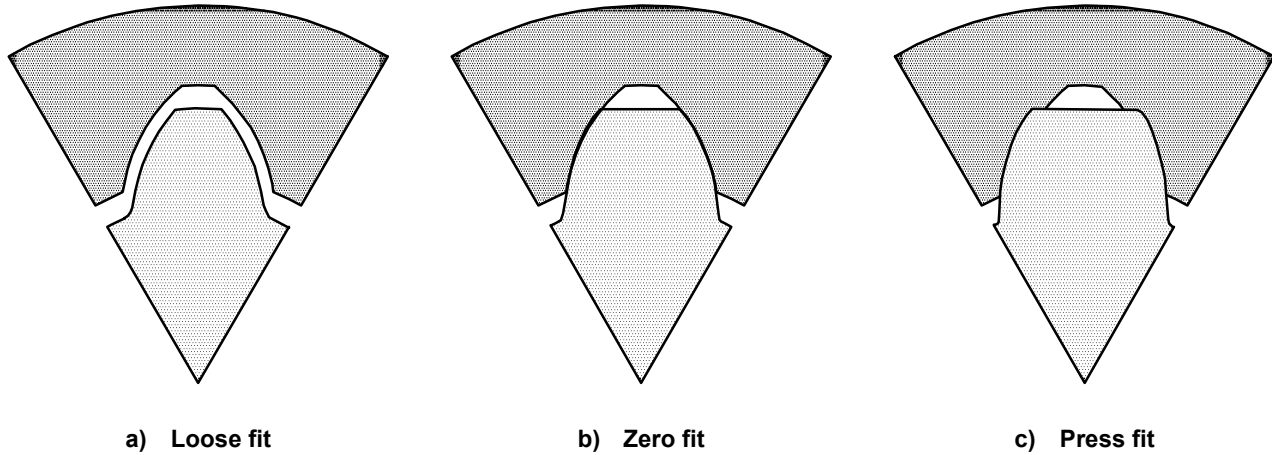
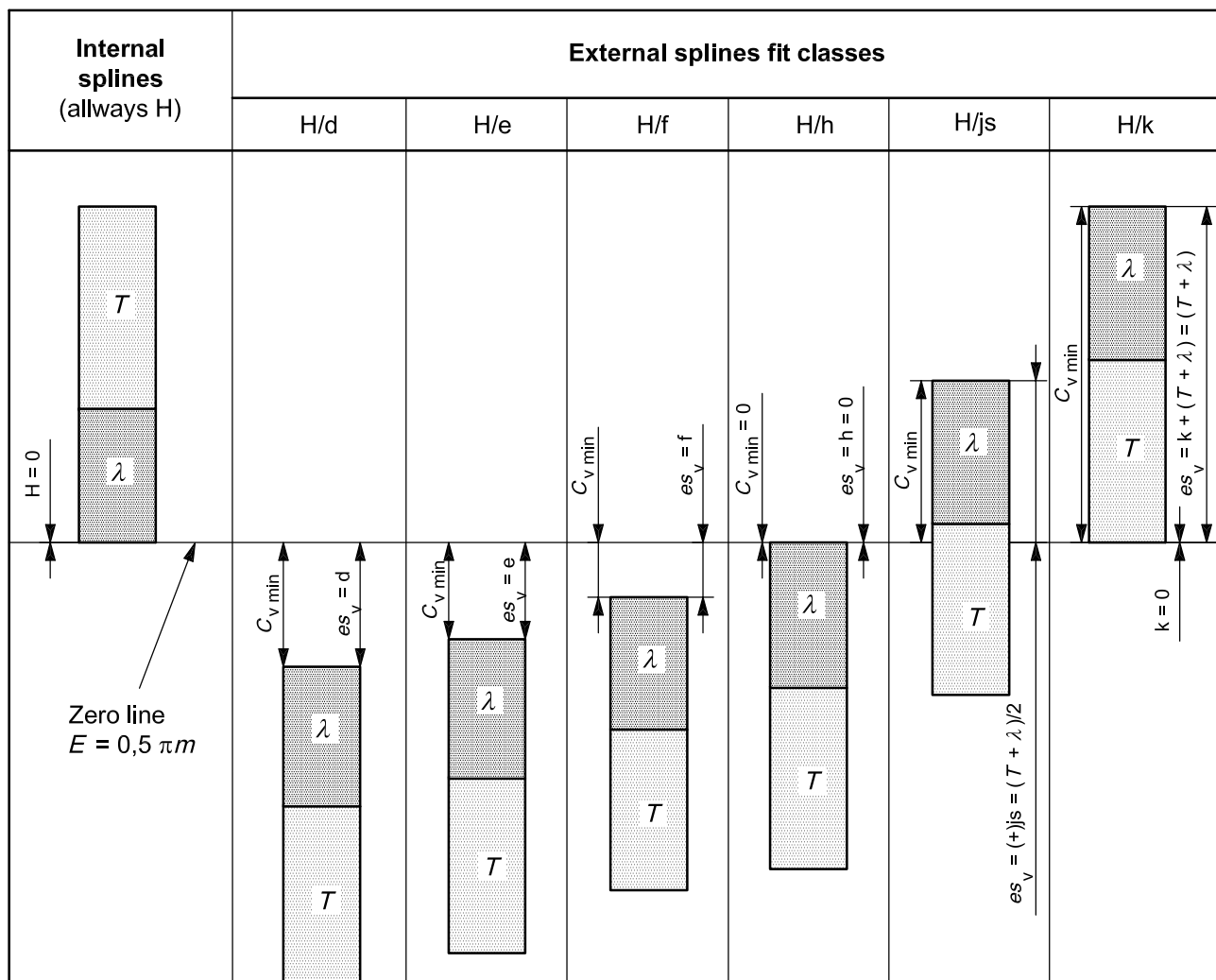

Figure 16 — Types of fit

This part of ISO 4156 provides standard fundamental deviation  $k$ ,  $js$ ,  $h$ ,  $f$ ,  $e$  and  $d$  for application to the circular tooth thickness ( $S$ ) at the pitch diameter of the external spline, in order to establish the spline fit classes without looseness or having maximum effective interferences or minimum effective clearances (see Table 6), and thus standardizing on composite GO gauges. Table 3 represents in graphical form the fundamental deviations and spline class tolerance zones for the six spline fit classes.

Table 3 — Graphical representation of fundamental deviations for spline fit classes



The required maximum effective interference or minimum effective looseness (see Table 4) shall be obtained by adjusting from the zero line the maximum effective tooth thickness by the fundamental deviation  $es_v$  (see Tables 3 and 5), whilst maintaining machining tolerance  $T$  and deviation allowance  $\lambda$ . The spline dimensions in the spline tables of ISO 4156-2 apply to class H/h.

Table 4 — Effective interference and effective looseness of spline fit classes

Spline fit class		Minimum effective looseness
H/d	$es_v = \text{fundamental deviation } d$	$c_{v \min} = -es_v$
H/e	$es_v = \text{fundamental deviation } e$	$c_{v \min} = -es_v$
H/f	$es_v = \text{fundamental deviation } f$	$c_{v \min} = -es_v$
H/h	$es_v = \text{fundamental deviation } h = \text{zero}$	$c_{v \min} = -es_v = \text{zero}$
H/js	$es_v = \text{fundamental deviation } js$	<b>Maximum effective interference</b> $c_{v \min} = -es_v = -(T + \lambda) / 2$
H/k	$es_v = (T + \lambda)$	$c_{v \min} = -es_v = -(T + \lambda)$

**Table 5 — Fundamental deviation  $es_v$**

Pitch diameter $D$ mm	Fundamental deviation $es_v$ $\mu\text{m}$ at pitch diameter $D$						
	Relative to tooth thickness $S$ for externals					Relative to space width $E$ for internals	
	For						
	d	e	f	h	js	k	H
$\leq 3$	-20	-14	-6	0	a	b	0
> 3 to 6	-30	-20	-10	0			0
> 6 to 10	-40	-25	-13	0			0
> 10 to 18	-50	-32	-16	0			0
> 18 to 30	-65	-40	-20	0			0
> 30 to 50	-80	-50	-25	0			0
> 50 to 80	-100	-60	-30	0			0
> 80 to 120	-120	-72	-36	0			0
> 120 to 180	-145	-85	-43	0			0
> 180 to 250	-170	-100	-50	0			0
> 250 to 315	-190	-110	-56	0			0
> 315 to 400	-210	-125	-62	0			0
> 400 to 500	-230	-135	-68	0			0
> 500 to 630	-260	-145	-76	0			0
> 630 to 800	-290	-160	-80	0			0
> 800 to 1 000	-320	-170	-86	0			0

<sup>a</sup>  $+(T + \lambda)/2$  relative to tolerance class considered; for  $T + \lambda$ , see 9.1.

<sup>b</sup>  $+(T + \lambda)$  relative to tolerance class considered; for  $T + \lambda$ , see 9.1.

## 9 Space width and tooth thickness tolerances

### 9.1 Total tolerance $T + \lambda$

This part of ISO 4156 includes four classes of total tolerance ( $T + \lambda$ ) on space width and tooth thickness selected from a combination of tolerance units ( $i$ ) in ISO 286-1. The tolerance classes are indicated in Table 6, with corresponding combination of tolerance units ( $i$ ).

**Table 6 — Total space width and tooth thickness tolerance ( $T + \lambda$ )**

Spline tolerance class	Total tolerance ( $T + \lambda$ ) $\mu\text{m}$
4	$T + \lambda = (10 \cdot i_d + 40 \cdot i_E)$
5	$T + \lambda = (16 \cdot i_d + 64 \cdot i_E)$
6	$T + \lambda = (25 \cdot i_d + 100 \cdot i_E)$
7	$T + \lambda = (40 \cdot i_d + 160 \cdot i_E)$

where

$$i_d = 0,45 \cdot \sqrt[3]{D} + 0,001 \cdot D \quad \text{for } D \leq 500 \text{ mm} \quad (1)$$

$$i_d = 0,004 \cdot D + 2,1 \quad \text{for } D > 500 \text{ mm} \quad (2)$$

$$i_E = 0,45 \cdot \sqrt[3]{E(\text{ou } S)} + 0,001 \cdot E(\text{or } S) \quad (3)$$

and

$D$  is the pitch diameter, in millimetres;

$E$  is the basic space width, in millimetres;

$S$  is the basic tooth thickness, in millimetres.

## 9.2 Deviation allowance, $\lambda$

The deviation allowance, being the accumulation of the total index deviation, total profile deviation and total helix deviation, has an effect on the effective fit of an involute spline. The effect of these individual spline deviations on the fit is less than their total, because areas of more than minimum clearance can have form, helix, or index errors without changing the fit. It is also unlikely that these errors would occur in their maximum amounts simultaneously on the same spline. For this reason, total index deviation, profile deviation and total helix deviation are added together statistically and 60 % of this total is taken to determine the effect that these deviations have on the spline fit. On this basis, the deviation allowance is calculated as follows:

$$\lambda = 0,6 \sqrt{F_p^2 + F_\alpha^2 + F_\beta^2} \quad (4)$$

In the following subclauses, the values of  $F_p$ ,  $F_\alpha$  and  $F_\beta$  are referenced to the datum of the effective spline axis. See ISO 4156-3.

## 9.3 Total pitch deviation, $F_p$

The total pitch deviation is the cumulative pitch error between the two greatest opposite pitch errors over any sector of one half circumference. The formulae given in Table 7 are used to calculate the total pitch deviation  $F_p$  expressed in micrometres.

Table 7 — Total pitch deviation

Spline tolerance class	Total pitch deviation $F_p$ $\mu\text{m}$
4	$F_p = 2,5 \cdot \sqrt{L} + 6,3$
5	$F_p = 3,55 \cdot \sqrt{L} + 9$
6	$F_p = 5 \cdot \sqrt{L} + 12,5$
7	$F_p = 7,1 \cdot \sqrt{L} + 18$

Where  $L$  is the length of the arc:

$$L = m \cdot z \cdot \pi / 2 \tag{5}$$

**9.4 Total profile deviation,  $F_\alpha$**

The total profile deviation is the absolute value of the difference between the greatest positive and negative deviations from the theoretical tooth profile, measured normal to the flanks. A positive deviation is in the direction of the space, and a negative deviation is in the direction of the tooth, as shown in Figure 17. The formulae given in Table 8 are used to calculate the total profile deviation  $F_\alpha$  expressed in micrometres.

Table 8 — Total profile deviation

Spline tolerance class	Total profile deviation $F_\alpha$ $\mu\text{m}$
4	$F_\alpha = 1,6 \cdot \varphi_f + 10$
5	$F_\alpha = 2,5 \cdot \varphi_f + 16$
6	$F_\alpha = 4 \cdot \varphi_f + 25$
7	$F_\alpha = 6,3 \cdot \varphi_f + 40$

Where  $\varphi_f$  is the tolerance factor:

$$\varphi_f = m + 0,012 5 \cdot m \cdot z \tag{6}$$

The permissible positive deviation on external splines and the negative deviation on internal splines from the design profile within the central one-third of the flank depth to the form diameter shall not exceed one-third of the calculated values. See Figure 17.

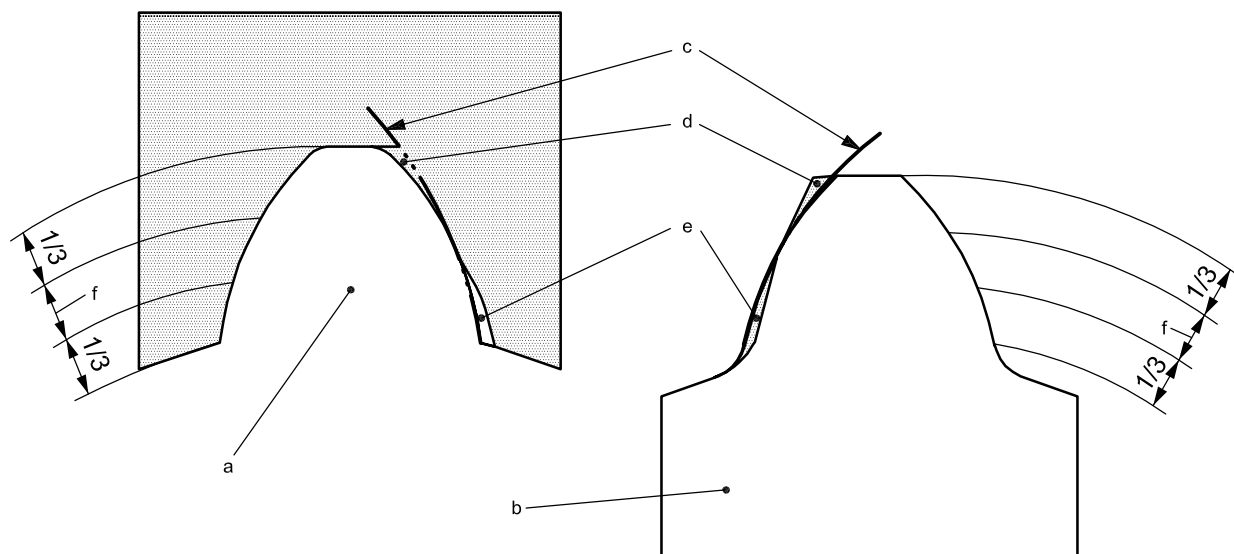

- a Space (internal).
- b Tooth (external).
- c Reference profile.
- d Positive profile deviation.
- e Negative profile deviation.
- f Centre third.

Figure 17 — Profile deviations

### 9.5 Total helix deviation, $F_{\beta}$

The total helix deviation is the absolute value of the difference between the two extreme deviations from the theoretical direction, measured normal to the flank for the full length of spline. The formulae given in Table 9 are used to calculate the total helix deviation  $F_{\beta}$ , expressed in micrometres.

Table 9 — Total helix deviation

Spline tolerance class	Total helix deviation $F_{\beta}$ $\mu\text{m}$
4	$F_{\beta} = 0,8 \cdot \sqrt{b} + 4$
5	$F_{\beta} = \sqrt{b} + 5$
6	$F_{\beta} = 1,25 \cdot \sqrt{b} + 6,3$
7	$F_{\beta} = 2 \cdot \sqrt{b} + 10$

*b* is the spline length, in millimetres.

### 9.6 Machining tolerance, $T$

The machining tolerance ( $T$ ) is derived from the difference between the total tolerance ( $T + \lambda$ ) and the deviation allowance  $\lambda$ , i.e.  $(T + \lambda) - \lambda$ . The division of total class tolerance between machining tolerance and deviation allowance outlined in clause 6 is recommended for general guidance. Design requirements or specific processes utilized for spline manufacture may require a different division.

$$T = (T + \lambda) - \lambda \quad (7)$$

**9.7 Effective clearance tolerance,  $T_v$**

If  $T_v$  is necessary, it is recommended that it be made equal to  $T$ .

**9.8 Use of effective and actual dimensions for space width and tooth thickness**

**9.8.1 Minimum material**

It is limited by maximum actual space width  $E_{max}$  and minimum actual tooth thickness  $S_{min}$  (see Figure 18 and Table 10).

**9.8.2 Maximum material (minimum effective clearance)**

It is limited by minimum effective space width  $E_{v min}$  and maximum effective tooth thickness  $S_{v max}$  (see Figure 18 and Table 10).

**9.8.3 Maximum effective clearance**

It is limited by maximum effective space width  $E_{v max}$  and minimum effective tooth thickness  $S_{v min}$  (see Figure 18 and Table 10). If it is necessary to control the effective tolerance band, then additional inspection is required.

Standard method	Alternative method A	Alternative method B
<p>Internal space width</p>	<p>Internal space width</p>	<p>Internal space width</p>

**Figure 18 — Graphical display of space width and tooth thickness tolerance zones according to inspection methods**

Table 10 — Relationship between parameters and control method

	Minimum material	Minimum effective clearance	Maximum effective clearance
Parameters	$S_{\min}/E_{\max}$	$S_{V \max}/E_{V \min}$	$S_{V \min}/E_{V \max}$
Standard method	X	X	—
Method A	X	X	X
Method B	—	X	X

## 10 Minor and major diameters

### 10.1 Tolerances

See Table 11.

Table 11 — Tolerances for minor diameter internal spline,  $D_{ii}$   
and for major diameter external spline,  $D_{ee}$

Diameter $D_{ii \min}$ or $D_{ee \max}$ mm	Tolerances on $D_{ii}$ $\mu\text{m}$ for modules $m$			Tolerances on $D_{ee}$ $\mu\text{m}$ for modules $m$		
	$m \leq 0,75$	$0,75 < m < 2$	$m \geq 2$	$m \leq 0,75$	$0,75 < m < 2$	$m \geq 2$
	H10	H11	H12	h10	h11	h12
$\leq 3$	+40 0			0 -40		
> 3 to 6	+48 0	+75 0		0 -48	0 -75	
> 6 to 10	+58 0	+90 0		0 -58	0 -90	
> 10 to 18	+70 0	+110 0	+180 0	0 -70	0 -110	0 -180
> 18 to 30	+84 0	+130 0	+210 0	0 -84	0 -130	0 -210
> 30 to 50	+100 0	+160 0	+250 0	0 -100	0 -160	0 -250
> 50 to 80	+120 0	+190 0	+300 0	0 -120	0 -190	0 -300
> 80 to 120		+200 0	+350 0		0 -220	0 -350
> 120 to 180		+250 0	+400 0		0 -250	0 -400
> 180 to 250			+460 0			0 -460
> 250 to 315			+520 0			0 -520
> 315 to 400			+570 0			0 -570
> 400 to 500			+630 0			0 -630
> 500 to 630			+700 0			0 -700
> 630 to 800			+800 0			0 -800
> 800 to 1 000			+900 0			0 -900

**10.2 Adjustment to minor diameters ( $D_{ie}$ ), form diameters ( $D_{Fe}$ ) and major diameters ( $D_{ee}$ ) of external splines**

When fundamental deviation d, e and f are applied to external splines, it is necessary to adjust the major, form and minor diameters. When applying js and k classes, the minor and form diameters only are adjusted, see formulae and notes in Table 1.

**11 Manufacturing and design considerations**

**11.1 Radii**

External splines may be produced by generating with a pinion-type shaper cutter or a hob, or by cutting with a no-generating motion using a tool formed to the contour of a tooth space. External splines are also made by cold forming, and in these cases are usually of the fillet root design. Internal splines are usually produced by broaching, by form cutting, or by generating with a shaper cutter. Even when full-tip radius tools are used, each of these cutting methods produces a fillet contour with individual characteristics. Generated spline fillets are curves related to the prolate epicycloid for external splines and the prolate hypocycloid for internal splines. These fillets have a minimum radius of curvature at the point where the fillet is tangent to the external spline minor diameter circle or the internal spline major diameter circle, and a rapidly increasing radius of curvature up to the point where the fillet becomes tangent to the involute profile.

The values in Table 12 may be used as minimum radii of curvature for stress calculations and specified as the minimum fillet radius. These values are based on the fillet radius shown on the basic rack profiles. For cutting of internal and external splines by generating, with the same pinion-type shaper cutter, the tool design will have to be made according to the dimensions of the internal splines to be obtained.

**Table 12 — Minimum root radius of internal or external splines**

Minimum root radius mm for			
$\alpha_D = 30^\circ$ flat root	$\alpha_D = 30^\circ$ fillet root	$\alpha_D = 37,5^\circ$	$\alpha_D = 45^\circ$
$0,2 m$	$0,4 m$	$0,3 m$	$0,25 m$

**11.2 Profile shifts**

In the manufacture of external splines with a standard fundamental deviation, standard cutters conforming to the basic rack can be used by shifting the basic rack reference line radially from its position touching the spline pitch circle. The spline tooth profiles remain as involutes; merely different parts of the same involutes, lying further inward or outward with respect to the pitch circle, are used. The amount of this radial displacement is equivalent to  $0,5es_v/\tan\alpha_D$ .

The effect of the various magnitudes of fundamental deviation ( $es_v$ ) on the tooth form have an effect on the circular tip thickness, at the major diameter of the external spline, which varies when the fundamental deviation ( $es_v$ ) varies. The following checks should be made when applying fundamental deviations :

- a) Check for tip thickness at major maximum diameter of external spline

A tip thickness of less than  $0,25 m$  should be avoided. Tip thickness is computed as follows, considering  $D_{ee \max}$ :

$$S_{ee} = D_{ee \max} \left[ (S_{\min}/D) + \text{inv } \alpha_D - \text{inv } \alpha_{Dee} \right] \tag{8}$$

where

$S_{ee}$  is the tip thickness;

$\alpha_D$  is the pressure angle at the pitch diameter;

$\alpha_{Dee}$  is the pressure angle at the maximum major diameter,

$$\cos \alpha_{Dee} = \frac{D_b}{D_{ee\max}} \quad (9)$$

$$\operatorname{inv} \alpha_D = \tan \alpha_D - \alpha_D \cdot \pi/180 \quad (10)$$

$$\operatorname{inv} \alpha_{Dee} = \tan \alpha_{Dee} - \alpha_{Dee} \cdot \pi/180 \quad (11)$$

$S_{\min}$  is the minimum actual tooth thickness.

#### b) Undercut fillet at the root circle (interference)

When a fit with looseness is selected, generating tools may produce undercut fillets on the external spline. Calculation using the appropriate tool data should be made to establish the presence or absence of undercutting and, if it exists, further calculations or a layout are then required to determine whether the degree of undercutting is acceptable.

Low tooth numbers and pressure angles introduce the risk of undercutting, which occurs with basic rack generation when

$$(h_s + 0,5 \cdot \Delta D_{ie}) > 0,5 \cdot D \cdot \sin^2 \alpha_D \quad (12)$$

### 11.3 Eccentricity and misalignment

#### 11.3.1 Eccentricity

The design assembly could make it necessary to apply a tolerance to the position of the effective spline axis and the functional axis of the part. To facilitate this, symbols from ISO 1101 shall be used. This part of ISO 4156 does not recommend any values, but they shall instead be defined according to the assembly requirements.

#### 11.3.2 Misalignment

If the assembly requires looseness or interference and the axis of the mating splines are misaligned, it will be necessary to increase the minimum effective clearance. This shall be accomplished by reducing the effective and actual tooth thickness of the external spline by an amount which is sufficient to allow the misaligned splines to assemble.

#### 11.3.3 Major and minor diameters

The eccentricity of major and minor diameters will not cause interference with the form diameters of the mating spline even when there is maximum clearance. However, if misalignment exists within the assembly, it will be necessary to reduce the major diameter of the external spline or increase the minor diameter of the internal spline.

## 12 Spline data

### 12.1 Basic dimensions

Spline data is used for engineering and manufacturing purposes.

### 12.2 Combination of types

Flat root side fit splines may be used with fillet root splines where the larger radius is desired for control of stress concentrations or manufacturing purposes. These combinations of spline roots may also be permitted as design options

The major diameter of a flat root internal spline and, if needed, the diameter at the tangency point of radius should be placed between the form diameter and the maximum major diameter of the fillet root internal spline.

### 12.3 Designation

The mating parts of straight cylindrical involute splines (metric modules, side fit) shall be designated in the following order:

Internal spline	= INT
External spline	= EXT
Mating splines	= INT/EXT
Number of teeth	= $z$ (preceded by the number)
Module	= $m$ (preceded by the value)
Pressure angle	= 30° flat root = 30 P
Pressure angle	= 30° fillet root = 30 R
Pressure angle	= 37,5° = 37,5
Pressure angle	= 45° = 45
Tolerance classes	= 4, 5, 6, 7
Fit class, internal spline	= H
Fit class, external spline	= k; js; h; f; e; d

ISO 4156

EXAMPLE Mating splines, 24 teeth; module 2,5; pressure angle 30° fillet root; tolerance class 5; fit

**Mating: INT/EXT 24z × 2,5m × 30R × 5H/5f ISO 4156**

**Internal spline: INT 24z × 2,5m × 30R × 5H ISO 4156**

**External spline: EXT 24z × 2,5m × 30R × 5f ISO 4156**

12.4 Drawing data

It is important that uniform specifications be used to show complete information on detail drawings of splines. Much misunderstanding will be avoided by following the suggested arrangement of dimensions and data, as shown in figure 19 and Table 13. The number of X indicates the number of decimal places normally used. With this charted type of spline specification, it is usually not necessary to give a graphical illustration of the spline teeth.

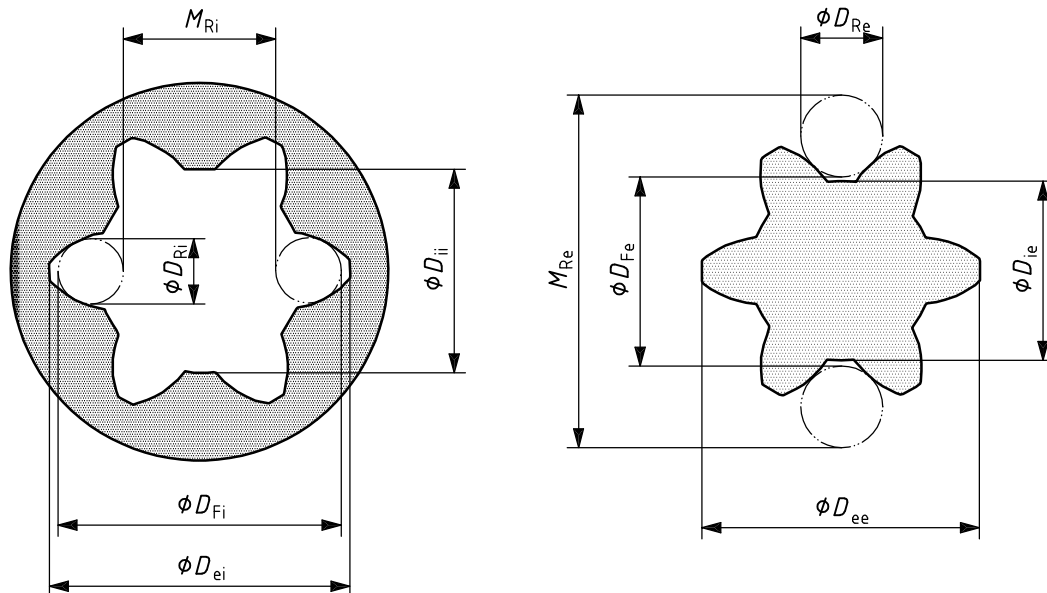

Figure 19 — Internal and external spline drawing dimensions

Table 13 — Spline terms and symbols

Internal spline ISO 4156			External spline ISO 4156		
Designation	see 12.3		Designation	see 12.3	
Number of teeth	$z$	.....	Number of teeth	$z$	.....
Module	$m$	.....	Module	$m$	.....
Pressure angle	$\alpha_D$	XX°	Pressure angle	$\alpha_D$	XX°
Pitch diameter	$D$	XX,XXXX <sup>a</sup>	Pitch diameter	$D$	XX,XXXX <sup>a</sup>
Base diameter	$D_b$	XX,XXXX <sup>a</sup>	Base diameter	$D_b$	XX,XXXX <sup>a</sup>
Major diameter	$D_{ei}$	XX,XX max.	Major diameter	$D_{ee}$	XX,XX h...
Form diameter	$D_{Fi}$	XX,XX min.	Form diameter	$D_{Fe}$	XX,XX max.
Minor diameter	$D_{ii}$	XX,XX H...	Minor diameter	$D_{ie}$	XX,XX min.
Space width <sup>b</sup>			Tooth thickness <sup>b</sup>		
max. actual	$E_{max}$	XX,XXX	max. effective	$S_{v\ max}$	XX,XXX
max. effective	$E_{v\ max}$	XX,XXX	max. actual	$S_{max}$	XX,XXX aux.
min. actual	$E_{min}$	XX,XXX aux.	min. effective	$S_{v\ min}$	XX,XXX
min. effective	$E_{v\ min}$	XX,XXX	min. actual	$S_{min}$	XX,XXX
Measurement between balls or pins	$M_{Ri}$	XX,XXX max. <sup>a</sup>	Measurement over balls or pins	$M_{Re}$	XX,XXX max. aux. <sup>a</sup>
Measurement between balls or pins	$M_{Ri}$	XX,XXX min. aux. <sup>a</sup>	Measurement over balls or pins	$M_{Re}$	XX,XXX min. <sup>a</sup>
Ball or pin diameter	$D_{Ri}$	X,XXX	Ball or pin diameter	$D_{Re}$	X,XXX
Fillet radius	See Table 2		Fillet radius	See Table 2	
<sup>a</sup> Calculated dimensions.					
<sup>b</sup> See 9.8.					

The values in Tables 14 to 17 are based on a length of engagement equal to one half of the pitch diameter. For a different length of engagement, adjustment of the deviation allowance could be required.

**Table 14 — Deviation allowances  $\lambda$  — Modules 0,25 to 1**

Tolerance values in micrometres

$z$ Number of teeth	$m = 0,25$ Tolerance class				$m = 0,5$ Tolerance class				$m = 0,75$ Tolerance class				$m = 1$ Tolerance class				$z$ Number of teeth
	4	5	6	7	4	5	6	7	4	5	6	7	4	5	6	7	
6	9	14	20	31	10	15	22	34	11	16	23	36	11	17	25	38	6
7	9	14	21	32	10	15	22	34	11	16	24	36	12	17	25	38	7
8	9	14	21	32	10	15	23	35	11	17	24	37	12	18	26	39	8
9	10	14	21	32	11	16	23	35	11	17	25	38	12	18	26	40	9
10	10	14	21	32	11	16	23	36	12	17	25	38	13	18	27	40	10
11	10	14	21	33	11	16	24	36	12	17	26	39	13	19	27	41	11
12	10	15	22	33	11	16	24	36	12	18	26	39	13	19	28	42	12
13	10	15	22	33	11	17	24	37	12	18	26	40	13	19	28	42	13
14	10	15	22	33	11	17	25	37	13	18	27	40	13	20	29	43	14
15	10	15	22	34	12	17	25	37	13	18	27	41	14	20	29	43	15
16	10	15	22	34	12	17	25	38	13	19	27	41	14	20	29	44	16
17	10	15	22	34	12	17	25	38	13	19	28	42	14	20	30	45	17
18	10	15	23	34	12	17	26	39	13	19	28	42	14	21	30	45	18
19	11	16	23	35	12	18	26	39	13	19	28	42	14	21	31	46	19
20	11	16	23	35	12	18	26	39	14	20	29	43	15	21	31	46	20
21	11	16	23	35	12	18	26	40	14	20	29	43	15	21	31	47	21
22	11	16	23	35	13	18	27	40	14	20	29	44	15	22	32	74	22
23	11	16	23	35	13	18	27	40	14	20	29	44	15	22	32	48	23
24	11	16	24	36	13	19	27	40	14	20	30	44	15	22	32	48	24
25	11	16	24	36	13	19	27	41	14	21	30	45	16	22	33	48	25
26	11	16	24	36	13	19	27	41	14	21	30	45	16	23	33	49	26
27	11	16	24	36	13	19	28	41	15	21	31	46	16	23	33	49	27
28	11	16	24	36	13	19	28	42	15	21	31	46	16	23	34	50	28
29	11	17	24	37	13	19	28	42	15	21	31	46	16	23	34	50	29
30	11	17	24	37	13	20	28	42	15	22	31	47	16	24	34	51	30
31	12	17	25	37	14	20	28	43	15	22	32	47	17	24	34	51	31
32	12	17	25	37	14	20	29	43	15	22	32	47	17	24	35	52	32
33	12	17	25	37	14	20	29	43	15	22	32	48	17	24	35	52	33
34	12	17	25	38	14	20	29	43	16	22	32	48	17	24	35	52	34
35	12	17	25	38	14	20	29	44	16	22	33	48	17	25	36	53	35
36	12	17	25	38	14	20	29	44	16	23	33	49	17	25	36	53	36
37	12	17	25	38	14	20	30	44	16	23	33	49	18	25	36	54	37
38	12	17	25	38	14	21	30	44	16	23	33	49	18	25	37	54	38
39	12	18	26	38	14	21	30	45	16	23	34	50	18	25	37	54	39
40	12	18	26	39	14	21	30	45	16	23	34	50	18	26	37	55	40
41	12	18	26	39	15	21	30	45	16	24	34	50	18	26	37	55	41
42	12	18	26	39	15	21	31	45	17	24	34	51	18	26	38	55	42
43	12	18	26	39	15	21	31	46	17	24	35	51	18	26	38	56	43
44	12	18	26	39	15	21	31	46	17	24	35	51	18	26	38	56	44
45	12	18	26	39	15	21	31	46	17	24	35	52	19	27	38	57	45
46	13	18	26	40	15	22	31	46	17	24	35	52	19	27	39	57	46
47	13	18	26	40	15	22	31	47	17	25	35	52	19	27	39	57	47
48	13	18	27	40	15	22	32	47	17	25	36	53	19	27	39	58	48
49	13	18	27	40	15	22	32	47	17	25	36	53	19	27	39	58	49
50	13	18	27	40	15	22	32	47	17	25	36	53	19	28	40	58	50
51	13	19	27	40	15	22	32	48	18	25	36	54	19	28	40	59	51
52	13	19	27	40	16	22	32	48	18	25	37	54	20	28	40	59	52
53	13	19	27	41	16	22	32	48	18	25	37	54	20	28	40	59	53
54	13	19	27	41	16	23	33	48	18	26	37	54	20	28	41	60	54
55	13	19	27	41	16	23	33	49	18	26	37	55	20	28	41	60	55
56	13	19	27	41	16	23	32	49	18	26	37	55	20	29	41	60	56
57	13	19	28	41	16	23	33	49	18	26	38	55	20	29	41	61	57
58	13	19	28	41	16	23	33	49	18	26	38	56	20	29	42	61	58
59	13	19	28	42	16	23	33	49	18	26	38	56	20	29	42	61	59
60	13	19	28	42	16	23	34	50	19	26	38	56	21	29	42	62	60
61	13	19	28	42	16	23	34	50	19	27	38	56	21	29	42	62	61
62	13	19	28	42	16	23	34	50	19	27	39	57	21	30	43	62	62
63	13	19	28	42	17	24	34	50	19	27	39	57	21	30	43	63	63
64	14	20	28	42	17	24	34	50	19	27	39	57	21	30	43	63	64
65	14	20	28	42	17	24	34	51	19	27	39	57	21	30	43	63	65
66	14	20	29	43	17	24	34	51	19	27	39	58	21	30	43	64	66
67	14	20	29	43	17	24	35	51	19	27	39	58	21	30	44	64	67
68	14	20	29	43	17	24	35	51	19	28	40	58	21	30	44	64	68
69	14	20	29	43	17	24	35	52	19	28	40	59	22	31	44	65	69
70	14	20	29	43	17	24	35	52	20	28	40	59	22	31	44	65	70
71	14	20	29	43	17	24	35	52	20	28	40	59	22	31	45	65	71
72	14	20	29	43	17	25	35	52	20	28	40	59	22	31	45	66	72
73	14	20	29	43	17	25	36	52	20	28	41	60	22	31	45	66	73
74	14	20	29	44	17	25	36	53	20	28	41	60	22	31	45	66	74
75	14	20	29	44	17	25	36	53	20	28	41	60	22	32	45	66	75
76	14	20	29	44	17	25	36	53	20	29	41	60	22	32	46	67	76
77	14	20	30	44	18	25	36	53	20	29	41	61	22	32	46	67	77
78	14	21	30	44	18	25	36	53	20	29	41	61	23	32	46	67	78
79	14	21	30	44	18	25	36	54	20	29	42	61	23	32	46	68	79
80	14	21	30	44	18	25	36	54	20	29	42	61	23	32	46	68	80
81	14	21	30	44	18	25	37	54	21	29	42	62	23	32	47	68	81
82	14	21	30	45	18	26	37	54	21	29	42	62	23	33	47	68	82
83	14	21	30	45	18	26	37	54	21	29	42	62	23	33	47	69	83
84	15	21	30	45	18	26	37	55	21	30	43	62	23	33	47	69	84
85	15	21	30	45	18	26	37	55	21	30	43	63	23	33	47	69	85
86	15	21	30	45	18	26	37	55	21	30	43	63	23	33	48	70	86
87	15	21	30	45	18	26	37	55	21	30	43	63	23	33	48	70	87
88	15	21	31	45	18	26	38	55	21	30	43	63	24	33	48	70	88
89	15	21	31	46	18	26	38	55	21	30	43	63	24	34	48	70	89
90	15	21	31	46	18	26	38	56	21	30	44	64	24	34	48	71	90
91	15	21	31	46	19	26	38	56	21	30	44	64	24	34	49	71	91
92	15	21	31	46	19	26	38	56	21	30	44	64	24	34	49	71	92
93	15	21	31	46	19	27	38	56	22	31	44	64	24	34	49	72	93
94	15	22	31	46	19	27	38	56	22	31	44	64	24	34	49	72	94
95	15	22	31	46	19	27	39	57	22	31	44	65	24	34	49	72	95
96	15	22	31	46	19	27	39	5									

Table 15 — Deviation allowances  $\lambda$  — Modules 1,25 to 2

Tolerance values in micrometres

$z$ Number of teeth	$m = 1,25$ Tolerance class				$m = 1,5$ Tolerance class				$m = 1,75$ Tolerance class				$m = 2$ Tolerance class				$z$ Number of teeth
	4	5	6	7	4	5	6	7	4	5	6	7	4	5	6	7	
6	12	18	26	40	13	18	27	41	13	19	28	43	14	20	29	44	6
7	12	18	27	40	13	19	28	42	13	20	29	44	14	20	30	45	7
8	13	19	27	41	13	19	29	43	14	20	30	45	14	21	31	47	8
9	13	19	28	42	14	20	29	44	14	21	30	46	15	22	32	48	9
10	13	19	28	43	14	20	30	45	15	21	31	47	15	22	32	49	10
11	14	20	29	43	14	21	30	46	15	22	32	48	16	23	33	49	11
12	14	20	29	44	15	21	31	46	15	22	32	48	16	23	34	50	12
13	14	20	30	45	15	22	31	47	16	23	33	49	16	23	34	51	13
14	14	21	30	45	15	22	32	48	16	23	33	50	17	24	35	52	14
15	15	21	31	46	15	22	32	48	16	23	34	51	17	24	36	53	15
16	15	21	31	47	16	23	33	49	16	24	35	52	17	25	36	54	16
17	15	22	32	47	16	23	33	50	17	24	35	52	17	25	37	55	17
18	15	22	32	48	16	23	34	51	17	24	36	53	18	26	37	55	18
19	15	22	33	48	16	24	34	51	17	25	36	54	18	26	38	56	19
20	16	23	33	49	17	24	35	52	18	25	37	54	18	26	38	57	20
21	16	23	33	50	17	24	35	52	18	26	37	55	19	27	39	58	21
22	16	23	34	50	17	25	36	53	18	26	38	56	19	27	39	58	22
23	16	24	34	51	17	25	36	54	18	26	38	56	19	28	40	59	23
24	17	24	35	51	18	25	37	54	19	27	39	57	19	28	40	60	24
25	17	24	35	52	18	26	37	55	19	27	39	58	20	28	41	60	25
26	17	24	35	52	18	26	37	55	19	27	39	58	20	29	41	61	26
27	17	25	36	53	18	26	38	56	19	28	40	59	20	29	42	62	27
28	17	25	36	53	18	26	38	57	19	28	40	60	20	29	42	62	28
29	17	25	36	54	19	27	39	57	20	28	41	60	21	30	43	63	29
30	18	25	37	54	19	27	39	58	20	28	41	61	21	30	43	64	30
31	18	26	37	55	19	27	39	58	20	29	42	61	21	30	44	64	31
32	18	26	37	55	19	28	40	59	20	29	42	62	21	31	44	65	32
33	18	26	38	56	19	28	40	59	21	29	42	62	22	31	45	66	33
34	18	26	38	56	20	28	41	60	21	30	43	63	22	31	45	66	34
35	19	27	38	57	20	28	41	60	21	30	43	64	22	31	45	67	35
36	19	27	39	57	20	29	41	61	21	30	44	64	22	32	46	67	36
37	19	27	39	58	20	29	42	61	21	30	44	65	22	32	46	68	37
38	19	27	39	58	20	29	42	62	22	31	44	65	23	32	47	69	38
39	19	27	40	58	21	29	42	62	22	31	45	66	23	33	47	69	39
40	19	28	40	59	21	30	43	63	22	31	45	66	23	33	48	70	40
41	20	28	40	59	21	30	43	63	22	32	46	67	23	33	48	70	41
42	20	28	41	60	21	30	43	64	22	32	46	67	23	33	48	71	42
43	20	28	41	60	21	30	44	64	22	32	46	68	24	34	49	71	43
44	20	29	41	61	21	30	44	65	23	32	47	68	24	34	49	72	44
45	20	29	41	61	22	31	44	65	23	33	47	69	24	34	49	72	45
46	20	29	42	61	22	31	45	66	23	33	47	69	24	35	50	73	46
47	20	29	42	62	22	31	45	66	23	33	48	70	24	35	50	74	47
48	21	29	42	62	22	31	45	66	23	33	48	70	25	35	51	74	48
49	21	30	43	63	22	32	46	67	24	34	48	71	25	35	51	75	49
50	21	30	43	63	22	32	46	67	24	34	49	71	25	36	51	75	50
51	21	30	43	63	23	32	46	68	24	34	49	72	25	36	52	76	51
52	21	30	44	64	23	32	47	68	24	34	49	72	25	36	52	76	52
53	21	30	44	64	23	33	47	69	24	35	50	73	26	36	52	77	53
54	21	31	44	65	23	33	47	69	24	35	50	73	26	37	53	77	54
55	22	31	44	65	23	33	47	70	25	35	50	74	26	37	53	78	55
56	22	31	44	65	23	33	48	70	25	35	51	74	26	37	53	78	56
57	22	31	44	66	23	33	48	70	25	35	51	75	26	37	54	79	57
58	22	31	45	66	24	34	48	71	25	36	51	75	26	38	54	79	58
59	22	32	45	67	24	34	49	71	25	36	52	76	27	38	55	80	59
60	22	32	46	67	24	34	49	72	25	36	52	76	27	38	55	80	60
61	22	32	46	67	24	34	49	72	26	36	52	76	27	38	55	81	61
62	23	32	46	68	24	34	50	72	26	37	53	77	27	39	56	81	62
63	23	32	46	68	24	35	50	73	26	37	53	77	27	39	56	82	63
64	23	32	47	68	24	35	50	73	26	37	53	78	27	39	56	82	64
65	23	33	47	69	25	35	50	74	26	37	54	78	28	39	57	82	65
66	23	33	47	69	25	35	51	74	26	37	54	79	28	39	57	83	66
67	23	33	48	70	25	36	51	74	26	38	54	79	28	40	57	83	67
68	23	33	48	70	25	36	51	75	27	38	54	79	28	40	57	84	68
69	23	33	48	70	25	36	51	75	27	38	55	80	28	40	58	84	69
70	24	33	48	70	25	36	52	76	27	38	55	80	28	40	58	85	70
71	24	34	48	71	25	36	52	76	27	38	55	81	29	41	58	85	71
72	24	34	49	71	26	36	52	76	27	39	56	81	29	41	59	86	72
73	24	34	49	71	26	37	53	77	27	39	56	82	29	41	59	86	73
74	24	34	49	72	26	37	53	77	28	39	56	82	29	41	59	87	74
75	24	34	49	72	26	37	53	77	28	39	56	82	29	41	60	87	75
76	24	35	50	72	26	37	53	78	28	39	57	83	29	42	60	87	76
77	24	35	50	73	26	37	54	78	28	40	57	83	30	42	60	88	77
78	25	35	50	73	26	37	54	79	28	40	57	84	30	42	61	88	78
79	25	35	50	73	27	38	54	79	28	40	58	84	30	42	61	89	79
80	25	35	51	74	27	38	54	79	28	40	58	84	30	43	61	89	80
81	25	35	51	74	27	38	55	80	29	40	58	85	30	43	62	90	81
82	25	35	51	74	27	38	55	80	29	41	58	85	30	43	62	90	82
83	25	36	51	75	27	38	55	80	29	41	59	86	30	43	62	90	83
84	25	36	51	75	27	39	55	81	29	41	59	86	31	43	62	91	84
85	25	36	52	75	27	39	56	81	29	41	59	86	31	44	63	91	85
86	25	36	52	76	27	39	56	81	29	41	60	87	31	44	63	92	86
87	26	36	52	76	28	39	56	82	29	42	60	87	31	44	63	92	87
88	26	36	52	76	28	39	56	82	29	42	60	87	31	44	64	92	88
89	26	37	53	77	28	39	57	82	30	42	60	88	31	44	64	93	89
90	26	37	53	77	28	40	57	83	30	42	61	88	31	45	64	93	90
91	26	37	53	78	28	40	57	83	30	43	61	89	32	45	64	94	91
92	26	37	53	78	28	40	57	83	30	43	61	89	32	45	65	94	92
93	26	37	53	78	28	40	58	84	30	43	61	89	32	45	65	94	93
94	26	38	54	78	28	40	58	84	30	43	62	90	32	45	65	95	94
95	26	38	54	79	29	40	58	84	30	43	62	90	32	46	66	95	95
96	27	38	54	79	29	41	58	85	31	43	62	90	32	46	66	96	96
97																	

Table 16 — Deviation allowances  $\lambda$  — Modules 2,5 to 5

Tolerance values in micrometres

$z$ Number of teeth	$m = 2,5$ Tolerance class				$m = 3$ Tolerance class				$m = 4$ Tolerance class				$m = 5$ Tolerance class				$z$ Number of teeth
	4	5	6	7	4	5	6	7	4	5	6	7	4	5	6	7	
6	14	21	31	47	15	22	33	50	17	25	37	56	18	27	40	61	6
7	15	22	32	49	16	23	34	52	18	26	38	57	19	28	41	62	7
8	15	23	33	50	16	24	35	53	18	27	39	59	20	29	43	64	8
9	16	23	34	51	17	25	36	54	19	27	40	60	20	30	44	66	9
10	16	24	35	52	17	25	37	55	19	28	41	62	21	31	45	67	10
11		24	35	53	18	26	38	57	20	29	42	63	22	31	46	69	11
12		25	36	54	18	26	39	58	20	29	43	64	22	32	47	70	12
13		25	37	55	19	27	39	59	21	30	44	66	23	33	48	72	13
14		26	38	56	19	28	40	60	21	31	45	67	23	34	49	73	14
15		26	38	57	19	28	41	61	22	31	46	68	24	34	50	75	15
16		27	39	58	20	29	42	62	22	32	47	69	24	35	51	76	16
17		27	40	59	20	29	42	63	23	33	48	70	25	36	52	77	17
18		28	40	60	21	30	43	64	23	33	48	72	25	36	53	79	18
19		28	41	61	21	30	44	65	23	34	49	73	26	37	54	80	19
20		29	42	62	21	31	44	66	24	34	50	74	26	38	55	81	20
21		29	42	62	22	31	45	67	24	35	51	75	27	38	56	82	21
22		29	43	63	22	32	46	68	25	35	51	76	27	39	57	84	22
23		30	43	64	22	32	46	69	25	36	52	77	28	39	57	85	23
24		30	44	65	23	32	47	69	25	36	53	78	28	40	58	86	24
25		31	44	66	23	33	48	70	26	37	54	79	28	41	59	87	25
26		31	45	66	23	33	48	71	26	37	54	80	29	41	60	88	26
27		31	45	67	24	34	49	72	27	38	55	81	29	42	61	89	27
28		32	46	68	24	34	49	73	27	38	56	82	30	42	61	90	28
29		32	47	69	24	35	50	74	27	39	56	83	30	43	62	92	29
30		33	47	69	24	35	51	74	28	39	57	84	30	43	63	93	30
31		33	48	70	25	35	51	75	28	40	58	85	31	44	64	94	31
32		33	48	71	25	36	52	76	28	40	58	86	31	44	64	95	32
33		34	49	71	25	36	52	77	29	41	59	87	31	45	65	96	33
34		34	49	72	26	37	53	78	29	41	60	88	32	45	66	97	34
35		34	50	73	26	37	53	78	29	42	60	88	32	46	67	98	35
36		35	50	73	26	37	54	79	29	42	61	89	33	46	67	99	36
37		35	51	74	26	38	54	80	30	42	62	90	33	47	68	100	37
38		35	51	75	27	38	55	81	30	43	62	91	33	47	69	101	38
39		36	51	75	27	38	55	81	30	43	63	92	34	48	69	102	39
40		36	52	76	27	39	56	82	31	44	63	93	34	48	70	103	40
41		36	52	77	27	39	56	83	31	44	64	94	34	49	71	103	41
42		37	53	77	28	39	57	83	31	45	64	94	35	49	71	104	42
43		37	53	78	28	40	57	84	32	45	65	95	35	50	72	105	43
44		37	54	79	28	40	58	85	32	45	66	96	35	50	73	106	44
45		37	54	79	28	40	58	85	32	46	66	97	36	51	73	107	45
46		38	55	80	29	41	59	86	32	46	67	98	36	51	74	108	46
47		38	55	80	29	41	59	87	33	47	67	98	36	51	74	109	47
48		38	55	81	29	41	60	87	33	47	68	99	36	52	75	110	48
49		39	56	82	29	42	60	88	33	47	68	100	37	52	76	111	49
50		39	56	82	30	42	61	89	34	48	69	101	37	53	76	112	50
51		39	57	83	30	42	61	89	34	48	69	101	37	53	77	112	51
52		40	57	83	30	43	62	90	34	48	70	102	38	54	77	113	52
53		40	57	84	30	43	62	91	34	49	70	103	38	54	78	114	53
54		40	58	85	30	43	63	91	35	49	71	104	38	54	79	115	54
55		40	58	85	31	44	63	92	35	49	71	104	39	55	79	116	55
56		41	59	86	31	44	63	93	35	50	72	105	39	55	80	117	56
57		41	59	86	31	44	64	93	35	50	73	106	39	56	81	117	57
58		41	59	87	31	45	64	94	36	51	73	107	39	56	81	118	58
59		42	60	87	32	45	65	94	36	51	74	107	40	56	82	119	59
60		42	60	88	32	45	65	95	36	51	74	108	40	57	82	120	60
61		42	61	88	32	45	66	96	36	52	75	109	40	57	83	121	61
62		42	61	89	32	46	66	96	37	52	75	109	41	58	83	121	62
63		43	61	89	32	46	66	97	37	52	75	110	41	58	84	122	63
64		43	62	90	33	46	67	97	37	53	76	111	41	58	84	123	64
65		43	62	91	33	47	67	98	37	53	76	111	41	59	85	124	65
66		43	62	91	33	47	68	99	38	53	77	112	42	59	85	124	66
67		44	63	92	33	47	68	99	38	54	77	113	42	59	86	125	67
68		44	63	92	33	47	68	100	38	54	78	113	42	60	86	126	68
69		44	64	93	34	48	69	100	38	54	78	114	42	60	87	127	69
70		44	64	93	34	48	69	101	38	55	79	115	43	61	87	128	70
71		45	64	94	34	48	70	101	39	55	79	115	43	61	88	128	71
72		45	65	94	34	49	70	102	39	55	80	116	43	61	89	129	72
73		45	65	95	34	49	70	102	39	56	80	117	43	62	89	130	73
74		45	65	95	35	49	71	103	39	56	81	117	44	62	90	130	74
75		46	66	96	35	49	71	104	40	56	81	118	44	62	90	131	75
76		46	66	96	35	50	72	104	40	57	82	119	44	63	91	132	76
77		46	66	97	35	50	72	105	40	57	82	119	44	63	91	133	77
78		46	67	97	35	50	72	105	40	57	82	120	45	63	92	133	78
79		47	67	98	36	50	73	106	41	57	83	121	45	64	92	134	79
80		47	67	98	36	51	73	106	41	58	83	121	45	64	93	135	80
81		47	68	99	36	51	73	107	41	58	84	122	45	64	93	136	81
82		47	68	99	36	51	74	107	41	58	84	122	46	65	94	136	82
83		48	68	99	36	51	74	108	41	59	85	123	46	65	94	137	83
84		48	69	100	37	52	74	108	42	59	85	124	46	65	95	138	84
85		48	69	100	37	52	75	109	42	59	85	124	46	66	95	138	85
86		48	69	101	37	52	75	109	42	60	86	125	47	66	95	139	86
87		48	70	101	37	52	76	110	42	60	86	126	47	66	96	140	87
88		49	70	102	37	53	76	110	42	60	87	126	47	67	96	140	88
89		49	70	102	37	53	76	111	43	60	87	127	47	67	97	141	89
90		49	71	103	38	53	77	111	43	61	88	127	48	67	97	142	90
91		49	71	103	38	53	77	112	43	61	88	128	48	68	98	142	91
92		50	71	104	38	54	77	112	43	61	88	128	48	68	98	143	92
93		50	72	104	38	54	78	113	43	62	89	129	48	68	99	144	93
94		50	72	105	38	54	78	113	44	62	89	130	48	69	99	144	94
95		50	72	105	38	54	78	114	44	62	90	130	49	69	100	145	95
96		50	73	105	39	55	79	114	44	62	90	131	49	69	100	146	96
97		51	73	106	39	55	79	115	44	63	90	131	49	70	101	146</	

Table 17 — Deviation allowances,  $\lambda$  — Modules 6 to 10

Tolerance values in micrometres

z Number of teeth	m = 6 Tolerance class				m = 8 Tolerance class				m = 10 Tolerance class				z Number of teeth
	4	5	6	7	4	5	6	7	4	5	6	7	
6	20	29	43	66	23	33	50	75	25	37	55	84	6
7	21	30	45	68	23	34	51	77	26	38	57	87	7
8	21	31	46	69	24	36	53	79	27	40	59	89	8
9	22	32	47	71	25	37	54	82	28	41	61	91	9
10	23	33	49	73	26	38	56	84	29	42	62	94	10
11	23	34	50	75	27	39	57	86	30	43	64	96	11
12	24	35	51	76	27	40	58	87	30	44	65	98	12
13	25	36	52	78	28	41	60	89	31	45	67	100	13
14	25	36	53	80	29	42	61	91	32	46	68	102	14
15	26	37	55	81	29	42	62	93	33	47	70	104	15
16	26	38	56	83	30	43	64	95	33	48	71	106	16
17	27	39	57	84	31	44	65	96	34	49	72	108	17
18	27	39	58	85	31	45	66	98	35	50	74	110	18
19	28	40	59	87	32	46	67	100	35	51	75	112	19
20	28	41	60	88	32	47	68	101	36	52	76	113	20
21	29	41	61	90	33	47	69	103	37	53	78	115	21
22	29	42	61	91	33	48	70	104	37	54	79	117	22
23	30	43	62	92	34	49	72	106	38	55	80	119	23
24	30	43	63	93	35	50	73	107	39	55	81	120	24
25	31	44	64	95	35	50	74	109	39	56	82	122	25
26	31	45	65	96	36	51	75	110	40	57	84	124	26
27	32	45	66	97	36	52	76	112	40	58	85	125	27
28	32	46	67	98	37	53	77	113	41	59	86	127	28
29	32	46	68	100	37	53	78	114	41	59	87	128	29
30	33	47	68	101	38	54	79	116	42	60	88	130	30
31	33	48	69	102	38	55	80	117	42	61	89	131	31
32	34	48	70	103	39	55	81	119	43	62	90	133	32
33	34	49	71	104	39	56	81	120	44	62	91	134	33
34	35	49	72	105	40	57	82	121	44	63	92	136	34
35	35	50	72	106	40	57	83	122	45	64	93	137	35
36	35	50	73	107	40	58	84	124	45	65	94	139	36
37	36	51	74	109	41	58	85	125	46	65	95	140	37
38	36	51	75	110	41	59	86	126	46	66	96	142	38
39	36	52	75	111	42	60	87	127	47	67	97	143	39
40	37	53	76	112	42	60	88	129	47	67	98	144	40
41	37	53	77	113	43	61	89	130	48	68	99	146	41
42	38	54	78	114	43	61	89	131	48	69	100	147	42
43	38	54	78	115	43	62	90	132	48	69	101	149	43
44	38	55	79	116	44	63	91	133	49	70	102	150	44
45	39	55	80	117	44	63	92	135	49	71	103	151	45
46	39	55	80	118	45	64	93	136	50	71	104	153	46
47	39	56	81	119	45	64	93	137	50	72	105	154	47
48	40	56	82	120	45	65	94	138	51	73	106	155	48
49	40	57	82	121	46	65	95	139	51	73	107	156	49
50	40	57	83	122	46	66	96	140	52	74	107	158	50
51	41	58	84	123	47	66	97	141	52	74	108	159	51
52	41	58	84	124	47	67	97	143	52	75	109	160	52
53	41	59	85	124	47	68	98	144	53	76	110	161	53
54	42	59	86	125	48	68	99	145	53	76	111	163	54
55	42	60	86	126	48	69	100	146	54	77	112	164	55
56	42	60	87	127	49	70	100	147	54	77	113	165	56
57	43	61	88	128	50	71	101	148	55	78	113	166	57
58	43	61	88	129	49	70	102	149	55	79	114	168	58
59	43	61	89	130	50	71	103	150	55	79	115	169	59
60	44	62	90	131	50	71	103	151	56	80	116	170	60
61	44	62	90	132	50	72	104	152	56	80	117	171	61
62	44	63	91	133	51	72	105	153	57	81	118	172	62
63	44	63	91	133	51	73	105	154	57	81	118	173	63
64	45	64	92	134	51	73	106	155	57	82	119	175	64
65	45	64	93	135	52	74	107	156	58	82	120	176	65
66	45	64	93	136	52	74	108	157	58	83	121	177	66
67	46	65	94	137	52	75	108	158	59	84	122	178	67
68	46	65	94	138	53	75	109	159	59	84	122	179	68
69	46	66	95	139	53	76	110	160	59	85	123	180	69
70	46	66	96	139	53	76	110	161	60	85	124	181	70
71	47	66	96	140	54	77	111	162	60	86	125	183	71
72	47	67	97	141	54	77	112	163	61	86	125	184	72
73	47	67	97	142	54	77	112	164	61	87	126	185	73
74	48	68	98	143	55	78	113	165	61	87	127	186	74
75	48	68	98	143	55	78	114	166	62	88	128	187	75
76	48	68	99	144	55	79	114	167	62	88	129	188	76
77	48	69	100	145	56	79	115	168	62	89	129	189	77
78	49	69	100	146	56	80	116	169	63	89	130	190	78
79	49	70	101	147	56	80	116	170	63	90	131	191	79
80	49	70	101	147	57	81	117	171	63	90	131	192	80
81	50	70	102	148	57	81	118	172	64	91	132	193	81
82	50	71	102	149	57	82	118	173	64	91	133	194	82
83	50	71	103	150	58	82	119	174	64	92	134	196	83
84	50	71	103	151	58	82	120	174	65	92	134	197	84
85	51	72	104	151	58	83	120	175	65	93	135	198	85
86	51	72	104	152	59	83	121	176	66	93	136	199	86
87	51	73	105	153	59	84	121	177	66	94	137	200	87
88	51	73	105	154	59	84	122	178	66	94	137	201	88
89	52	73	106	154	59	85	123	179	67	95	138	202	89
90	52	74	106	155	60	85	123	180	67	95	139	203	90
91	52	74	107	156	60	85	124	181	67	96	139	204	91
92	52	74	108	157	60	86	124	182	68	96	140	205	92
93	53	75	108	157	61	86	125	183	68	97	141	206	93
94	53	75	109	158	61	87	126	183	68	97	141	207	94
95	53	75	109	159	61	87	126	184	69	98	142	208	95
96	53	76	110	160	62	87	127	185	69	98	143	209	96
97	54	76	110	160	62	88	127	186	69	99	143	210	97
98	54	76	111	161	62	88	128	187	70	99	144	211	98
99	54	77	111	162	62	89	129	188	70	100	145	212	99
100	54	77	112	162	63	89	129	189	70	100	145	213	100

## Annex A (informative)

### Drawing data example calculations

#### A.1 General

ISO 4156-2 provides drawing data for spline fit class H/h. The following example calculations are provided to show how this data is calculated, and also to provide a guide for the calculation of drawing data for the non-tabulated spline fit classes.

#### A.2 INT 25z × 1,0 m × 30P × 5H - ISO 4156

NOTE Unless otherwise stated, all formulae are provided in Table 1.

Number of teeth	$z = 25$
Module	$m = 1,0$
Pressure angle	$\alpha_D = 30^\circ$
Pitch diameter	$D = m \cdot z = 1,0 \cdot 25 = 25,000\ 0$
Base diameter	$D_b = m \cdot z \cdot \cos \alpha_D = 1,0 \cdot 25 \cdot \cos(30^\circ) = 21,650\ 635\ 09 = 21,650\ 6$
Minimum major diameter ( <i>flat</i> root) — not tabulated but necessary for calculating maximum major diameter.	
	$D_{ei\ min} = m \cdot (z + 1,5) = 1,0 \cdot (25 + 1,5) = 26,50$
Maximum major diameter	$D_{ei\ max} = D_{ei\ min} + (T + \lambda) / \tan \alpha_D$
From 9.1	class 7 $(T + \lambda) = 40 \cdot i_d + 160 \cdot i_E$
	$i_d = 0,45 \cdot \sqrt[3]{D} + 0,001 \cdot D = 0,45 \cdot \sqrt[3]{25,0} + 0,001 \cdot 25,0 = 1,340\ 8$
	$i_E = 0,45 \cdot \sqrt[3]{E} + 0,001 \cdot E$
	$E = 0,5 \cdot \pi \cdot m = 0,5 \cdot \pi \cdot 1,0 = 1,571$
	$i_E = 0,45 \cdot \sqrt[3]{1,571} + 0,001 \cdot 1,571 = 0,524\ 7$
	$T + \lambda = 40 \cdot 1,3408 + 160 \cdot 0,5247 = 137,584\ \mu\text{m} = 0,138\ \text{mm}$
	$D_{ei\ max} = 26,50 + 0,138 / \tan(30^\circ) = 26,74$
Form diameter	$D_{Fi\ min} = m \cdot (z + 1) + 2 \cdot c_F$
	$c_F = 0,1 \cdot 1,0 = 0,1$
	$D_{Fi\ min} = 1,0 \cdot (25 + 1) + 2 \cdot 0,1 = 26,20$

Minor diameter

$$D_{ii \min} = D_{Fe \max} + 2 \cdot c_F$$

$$D_{Fe \max} = 2 \cdot \sqrt{(0,5 \cdot D_b)^2 + \left(0,5 \cdot D \cdot \sin \alpha_D - \frac{h_s - \frac{0,5 \cdot es_v}{\tan \alpha_D}}{\sin \alpha_D}\right)^2}$$

From Table 2

$$h_s = 0,6 \cdot m = 0,6 \cdot 1,0 = 0,6$$

From Table 5

$$es_v = 0 \quad (\text{see Table 1, Note 2})$$

$$D_{Fe \max} = 2 \cdot \sqrt{(0,5 \cdot 21,650 \, 64)^2 + \left(0,5 \cdot 25,0 \cdot \sin(30^\circ) - \frac{0,6 - \frac{0,5 \cdot 0}{\tan(30^\circ)}}{\sin(30^\circ)}\right)^2}$$

$$D_{Fe \max} = 23,89$$

$$D_{ii \min} = 23,89 + 2 \cdot 0,1 = 24,09$$

$$D_{ii} = 24,09 \text{ H11 } (+0,130/0)$$

Minimum effective space width  $E_{v \min} = 0,5 \cdot \pi \cdot m = 0,5 \cdot \pi \cdot 1,0$ 

$$E_{v \min} = 1,571$$

Maximum actual space width  $E_{\max} = E_{v \min} + (T + \lambda)$ 

From 9.1

$$\text{class 5 } (T + \lambda) = 16 \cdot i_d + 64 \cdot i_E$$

From above formula

$$i_d = 1,3408 \text{ and } i_E = 0,5247$$

$$T + \lambda = 16 \cdot 1,3408 + 64 \cdot 0,5247 = 55,03 \, \mu\text{m} = 0,055 \text{ mm}$$

$$E_{\max} = 1,571 + 0,055 = 1,626$$

Minimum actual space width  $E_{\min} = E_{v \min} + \lambda$ 

NOTE  $\lambda$  can be calculated from total pitch deviation ( $F_p$ ), total profile deviation ( $F_a$ ) and total helix deviation ( $F_\beta$ ), see 9.2; or else can be obtained from Table 14.

Total pitch deviation  $F_p = 3,55 \cdot \sqrt{L} + 9$  (formula from Table 7)where  $L = m \cdot z \cdot \frac{\pi}{2} = 1,0 \cdot 25 \cdot \frac{\pi}{2} = 39,269 \, 908 \, 17$ 

$$F_p = 3,55 \cdot \sqrt{39,269 \, 908 \, 17} + 9 = 31,25 \, \mu\text{m} = 0,031 \text{ mm}$$

Total profile deviation  $F_\alpha = 2,5 \cdot \varphi_f + 16$  (formula from Table 8)

where  $\varphi_f = m + 0,0125 \cdot m \cdot z = 1,0 + 0,0125 \cdot 1,0 \cdot 25 = 1,31250$

$$F_\alpha = 2,5 \cdot 1,31250 + 16 = 19,28 \mu\text{m} = 0,019 \text{ mm}$$

Total helix deviation  $F_\beta = \sqrt{b} + 5$  (formula from Table 9)

where  $b = \text{length of spline}$  (assume to be one half of the pitch diameter)

$$b = \frac{D}{2} = \frac{25}{2} = 12,50$$

$$F_\beta = \sqrt{12,50} + 5 = 8,54 \mu\text{m} = 0,009 \text{ mm}$$

Deviation allowance  $\lambda = 0,6 \cdot \sqrt{F_p^2 + F_\alpha^2 + F_\beta^2}$

$$\lambda = 0,6 \cdot \sqrt{0,031^2 + 0,019^2 + 0,009^2}$$

$$\lambda = 0,022$$

$$E_{\min} = 1,571 + 0,022 = 1,593$$

Max. effective space width  $E_{V \max} = E_{\max} - \lambda$

$$E_{V \max} = 1,626 - 0,022 = 1,604$$

Measuring ball or pin diameter  $D_{Ri}$  (formulae taken from ISO 4156-3:2005, 8.5.2)

$$\widehat{DE}_i = E \cdot \cos \alpha_D + D_b \cdot \text{inv} \alpha_D$$

where  $\text{inv} \alpha_D = \tan \alpha_D - \left( \alpha_D \cdot \frac{2 \cdot \pi}{360^\circ} \right) = \tan(30^\circ) - \left( 30^\circ \cdot \frac{2 \cdot \pi}{360^\circ} \right) = 0,05375$

$$\widehat{DE}_i = 1,571 \cdot \cos(30^\circ) + 21,65064 \cdot 0,05375 = 2,52425$$

$$\overline{BA} = \frac{D_b \cdot \tan \alpha_D}{2} = \frac{21,65064 \cdot \tan(30^\circ)}{2} = 6,25000$$

$$\overline{BO}_i = \frac{D_b \cdot \tan \left( \alpha_D + \text{inv} \alpha_D - \frac{\widehat{DE}_i}{D_b} \right)}{2}$$

$$\overline{BO}_i = \frac{21,65064 \cdot \tan \left[ \left( 30^\circ \cdot \frac{2 \cdot \pi}{360^\circ} + 0,05375 - \frac{2,52425}{21,65064} \right) \cdot \frac{360^\circ}{2 \cdot \pi} \right]}{2} = 5,37362$$

Calculated  $D_{Ri} = 2 \cdot (\overline{BA} - \overline{BO}_i) = 2 \cdot (6,250 - 5,373\ 62) = 1,752\ 76$

From ISO 3 R40 no. series  $D_{Ri} = 1,800$

Maximum measurement between balls or pins  $M_{Ri\ max}$  (formulae taken from ISO 4156-3:2005, 8.6.1.2)

From above formula  $D_{Ri} = 1,800$

$$\text{inv } \alpha_i = \frac{E}{D} + \left( \text{inv } \alpha_D - \frac{D_{Ri}}{D_b} \right)$$

$$E = E_{\max} = 1,626$$

$$\text{inv } \alpha_i = \frac{1,626}{25,000} + \left( 0,053\ 75 - \frac{1,800}{21,650\ 64} \right) = 0,035\ 651\ 58$$

$$\alpha_i = 26,403\ 30^\circ$$

For odd numbers of teeth  $M_{Ri\ max} = \frac{D_b \cdot \cos \frac{90^\circ}{z}}{\cos \alpha_i} - D_{Ri}$

$$M_{Ri\ max} = \frac{21,650\ 64 \cdot \cos \left( \frac{90^\circ}{25} \right)}{\cos(26,403\ 30^\circ)} - 1,800 = 22,324$$

Minimum measurement between balls or pins  $M_{Ri\ min}$

$$E = E_{\min} = 1,593$$

$$\text{inv } \alpha_i = \frac{1,593}{25,000} + \left( 0,053\ 75 - \frac{1,800}{21,650\ 64} \right) = 0,034\ 331\ 58$$

$$\alpha_i = 26,092\ 26^\circ$$

$$M_{Ri\ min} = \frac{21,650\ 64 \cdot \cos \left( \frac{90^\circ}{25} \right)}{\cos(26,092\ 26^\circ)} - 1,800 = 22,260$$

Fillet radius  $\rho_{Fi} = 0,2m$  (formula from Table 2)

$$\rho_{Fi} = 0,2 \times 1,0 = 0,2$$

**A.3 INT 25z × 1,0m × 30R × 7H - ISO 4156**

In this example, a length of spline of spline of 25,0 mm has been used to calculate total helix deviation and hence the deviation allowance.

NOTE Unless otherwise stated all formulae are provided in Table 1.

Number of teeth  $z = 25$

Module  $m = 1,0$

Pressure angle  $\alpha_D = 30^\circ$

Pitch diameter  $D = m \cdot z = 1,0 \times 25 = 25,000 0$

Base diameter  $D_b = m \cdot z \cdot \cos \alpha_D = 1,0 \cdot 25 \cdot \cos(30^\circ) = 21,650 635 09 = 21,650 6$

Minimum major diameter (*fillet* root) — not tabulated but necessary for calculating maximum major diameter.

$$D_{ei \min} = m \cdot (z + 1,8) = 1,0 \times (25 + 1,8) = 26,80$$

Maximum major diameter  $D_{ei \max} = D_{ei \min} + (T + \lambda) / \tan \alpha_D$

From 9.1 class 7  $(T + \lambda) = 40 \cdot i_d + 160 i_E$

$$i_d = 0,45 \cdot \sqrt[3]{D} + 0,001 \cdot D = 0,45 \cdot \sqrt[3]{25,0} + 0,001 \cdot 25,0 = 1,340 8$$

$$i_E = 0,45 \cdot \sqrt[3]{E} + 0,001 \cdot E$$

$$E = 0,5 \cdot \pi \cdot m = 0,5 \cdot \pi \cdot 1,0 = 1,571$$

$$i_E = 0,45 \cdot \sqrt[3]{1,571} + 0,001 \cdot 1,571 = 0,5247$$

$$T + \lambda = 40 \cdot 1,340 8 + 160 \cdot 0,524 7 = 137,584 \mu\text{m} = 0,138 \text{ mm}$$

$$D_{ei \max} = 26,80 + 0,138 / \tan(30^\circ) = 27,04$$

Form diameter  $D_{Fi \min} = m \cdot (z + 1) + 2 \cdot c_F$

$$c_F = 0,1 \cdot 1,0 = 0,1$$

$$D_{Fi \min} = 1,0 \cdot (25 + 1) + 2 \cdot 0,1 = 26,20$$

Minor diameter  $D_{ii \min} = D_{Fe \max} + 2 \cdot c_F$

$$D_{Fe \max} = 2 \cdot \sqrt{(0,5 \cdot D_b)^2 + \left(0,5 \cdot D \cdot \sin \alpha_D - \frac{h_s \cdot 0,5 \cdot es_v}{\tan \alpha_D}\right)^2}$$

From Table 2  $h_s = 0,6 \cdot m = 0,6 \cdot 1,0 = 0,6$

From Table 5  $es_v = 0$  (see Table 1, Note 2)

$$D_{Fe \max} = 2 \cdot \sqrt{(0,5 \times 21,650\ 64)^2 + \left(0,5 \times 25,0 \times \sin(30^\circ) - \frac{0,6 - \frac{0,5 \times 0}{\tan(30^\circ)}}{\sin(30^\circ)}\right)^2}$$

$$D_{Fe \max} = 23,89$$

$$D_{ii \min} = 23,89 + 2 \cdot 0,1 = 24,09$$

$$D_{ij} = 24,09 \text{ H11 } (+0,130/0)$$

Min. effective space width  $E_{v \min} = 0,5 \cdot \pi \cdot m = 0,5 \cdot \pi \cdot 1,0$

$$E_{v \min} = 1,571$$

Max. actual space width  $E_{\max} = E_{v \min} + (T + \lambda)$

From above formula class 7  $(T + \lambda) = 0,138$

$$E_{\max} = 1,571 + 0,138 = 1,709$$

Min. actual space width  $E_{\min} = E_{v \min} + \lambda$

NOTE  $\lambda$  can be calculated from total pitch deviation ( $F_p$ ) total profile deviation ( $F_\alpha$ ) and total helix deviation ( $F_\beta$ ), see 9.2, or  $\lambda$  can be obtained from Table 14.

Total pitch deviation  $F_p = 7,1 \cdot \sqrt{L} + 18$  (formula from Table 7)

where  $L = m \times z \times \frac{\pi}{2} = 1,0 \times 25 \times \frac{\pi}{2} = 39,269\ 908\ 17$

$$F_p = 7,1 \times \sqrt{39,269\ 908\ 17} + 18 = 62,49\ \mu\text{m} = 0,062\ \text{mm}$$

Total profile deviation  $F_\alpha = 6,3 \times \varphi_f + 40$  (formula from Table 8)

where  $\varphi_f = m + 0,012\ 5 \times m \times z = 1,0 + 0,012\ 5 \times 1,0 \times 25 = 1,312\ 50$

$$F_\alpha = 6,3 \times 1,312\ 50 + 40 = 48,27\ \mu\text{m} = 0,048\ \text{mm}$$

Total helix deviation  $F_\beta = 2 \cdot \sqrt{b} + 10$  (formula from Table 9)

where  $b =$  length of spline (assume to be 25,0 mm)

$$F_\beta = 2 \times \sqrt{25,0} + 10 = 20,00\ \mu\text{m} = 0,020\ \text{mm}$$

Deviation allowance  $\lambda = 0,6 \cdot \sqrt{F_p^2 + F_\alpha^2 + F_\beta^2}$

$$\lambda = 0,6 \cdot \sqrt{0,062^2 + 0,048^2 + 0,020^2}$$

$$\lambda = 0,049$$

$$E_{\min} = 1,571 + 0,049 = 1,620$$

Max. effective space width  $E_{V \max} = E_{\max} - \lambda$

$$E_{V \max} = 1,709 - 0,049 = 1,660$$

Measuring ball or pin diameter  $D_{Ri}$  (formulae taken from ISO 4156-3:2005, 8.5.2)

$$\widehat{DE}_i = E \cdot \cos \alpha_D + D_b \cdot \text{inv} \alpha_D$$

where  $\text{inv} \alpha_D = \tan \alpha_D - \left( \alpha_D \times \frac{2 \times \pi}{360^\circ} \right) = \tan(30^\circ) - \left( 30^\circ \times \frac{2 \times \pi}{360^\circ} \right) = 0,053 75$

$$\widehat{DE}_i = 1,571 \cdot \cos(30^\circ) + 21,650 64 \cdot 0,053 75 = 2,524 25$$

$$\overline{BA} = \frac{D_b \times \tan \alpha_D}{2} = \frac{21,650 64 \times \tan(30^\circ)}{2} = 6,250 00$$

$$\overline{BO}_i = \frac{D_b \times \tan \left( \alpha_D + \text{inv} \alpha_D - \frac{\widehat{DE}_i}{D_b} \right)}{2}$$

$$\overline{BO}_i = \frac{21,650 64 \times \tan \left[ \left( 30^\circ \times \frac{2 \times \pi}{360^\circ} + 0,053 75 - \frac{2,524 25}{21,650 64} \right) \times \frac{360^\circ}{2 \times \pi} \right]}{2} = 5,373 62$$

Calculated  $D_{Ri} = 2 \cdot (\overline{BA} - \overline{BO}_i) = 2 \cdot (6,250 - 5,373 62) = 1,752 76$

From ISO R40 no. series  $D_{Ri} = 1,800$

Maximum measurement between balls or pins  $M_{Ri \max}$  (formulae taken from ISO 4156-3:2005, 8.6.1.2)

From above formula  $D_{Ri} = 1,800$

$$\text{inv} \alpha_i = \frac{E}{D} + \left( \text{inv} \alpha_D - \frac{D_{Ri}}{D_b} \right)$$

$$E = E_{\max} = 1,709$$

$$\text{inv} \alpha_i = \frac{1,709}{25,000} + \left( 0,053 75 - \frac{1,800}{21,650 64} \right) = 0,038 971 58$$

$$\alpha_i = 27,150 21^\circ$$

For odd numbers of teeth  $M_{Ri \max} = \frac{D_b \times \cos \frac{90^\circ}{z}}{\cos \alpha_i} - D_{Ri}$

$$M_{Ri \max} = \frac{21,650\ 64 \cdot \cos\left(\frac{90^\circ}{25}\right)}{\cos(27,150\ 21^\circ)} - 1,800 = 22,484$$

Min. measurement between balls or pins  $M_{Ri \min}$

$$E = E_{\min} = 1,620$$

$$\operatorname{inv} \alpha_i = \frac{1,620}{25,000} + \left(0,053\ 75 - \frac{1,800}{21,650\ 64}\right) = 0,035\ 411\ 58$$

$$\alpha_i = 26,347\ 37^\circ$$

$$M_{Ri \min} = \frac{21,650\ 64 \times \cos\left(\frac{90^\circ}{25}\right)}{\cos(26,347\ 37^\circ)} - 1,800 = 22,313$$

Fillet radius  $\rho_{Fi} = 0,4 \times m$  (formula from Table 2)

$$\rho_{Fi} = 0,4 \times 1,0 = 0,4$$

#### A.4 EXT 25z × 1,0m × 30P × 4h - ISO 4156

NOTE Unless otherwise stated all formulae are provided in Table 1.

Number of teeth  $z = 25$

Module  $m = 1,0$

Pressure angle  $\alpha_D = 30^\circ$

Pitch diameter  $D = m \cdot z = 1,0 \cdot 25 = 25,000\ 0$

Base diameter  $D_b = m \cdot z \cdot \cos \alpha_D = 1,0 \cdot 25 \cdot \cos(30^\circ) = 21,650\ 635\ 09 = 21,650\ 6$

Major diameter  $D_{ee \max} = m \cdot (z + 1) + \frac{es_v}{\tan \alpha_D}$

From Table 5  $es_v = 0$

$$D_{ee \max} = 1,0 \times (25 + 1) + \frac{0}{\tan(30^\circ)} = 26,00$$

$$D_{ee} = 26,00\ h11\ (0/-0,130)$$

Form diameter

$$D_{Fe \max} = 2 \cdot \sqrt{(0,5 \cdot D_b)^2 + \left(0,5 \cdot D \cdot \sin \alpha_D - \frac{h_s - \frac{0,5 \cdot es_v}{\tan \alpha_D}}{\sin \alpha_D}\right)^2}$$

From Table 2  $h_s = 0,6 \times m = 0,6 \times 1,0 = 0,6$

From Table 5  $es_v = 0$

$$D_{Fe \max} = 2 \times \sqrt{(0,5 \times 21,650\ 64)^2 + \left( 0,5 \times 25,0 \times \sin(30^\circ) - \frac{0,6 - \frac{0,5 \times 0}{\tan(30^\circ)}}{\sin(30^\circ)} \right)^2}$$

$D_{Fe \max} = 23,89$

Maximum minor diameter (*flat root*) — not tabulated but necessary for calculating minimum minor diameter.

$$D_{ie \max} = m \cdot (z - 1,5) + \frac{es_v}{\tan \alpha_D} = 1,0 \cdot (25 - 1,5) + \frac{0}{\tan(30^\circ)} = 23,50$$

Minimum minor diameter  $D_{ie \min} = D_{ie \max} - \frac{(T + \lambda)}{\tan \alpha_D}$

From 9.1 class 7  $(T + \lambda) = 40 \cdot i_d + 160 i_E$

$$i_d = 0,45 \cdot \sqrt[3]{D} + 0,001 \cdot D = 0,45 \cdot \sqrt[3]{25,0} + 0,001 \cdot 25,0 = 1,340\ 8$$

$$i_E = 0,45 \cdot \sqrt[3]{E} + 0,001 \cdot E$$

$$E = 0,5 \cdot \pi \cdot m = 0,5 \cdot \pi \cdot 1,0 = 1,571$$

$$i_E = 0,45 \cdot \sqrt[3]{1,571} + 0,001 \cdot 1,571 = 0,524\ 7$$

$$T + \lambda = 40 \cdot 1,340\ 8 + 160 \cdot 0,524\ 7 = 137,584\ \mu\text{m} = 0,138\ \text{mm}$$

$$D_{ie \min} = 23,50 - \frac{0,138}{\tan(30^\circ)} = 23,26$$

Max. effective tooth thickness  $S_{v \max} = S + es_v$

$$S = 0,5 \times \pi \times m = 0,5 \times \pi \times 1,0 = 1,571$$

$$S_{v \max} = 1,571 + 0 = 1,571$$

Min. actual tooth thickness  $S_{\min} = S_{v \max} - (T + \lambda)$

From 9.1 class 4  $(T + \lambda) = 10 \cdot i_d + 40 \cdot i_E$

From above formula  $i_d = 1,340\ 8$  et  $i_E = 0,524\ 7$

$$T + \lambda = 10 \times 1,340\ 8 + 40 \times 0,524\ 7 = 34,396\ \mu\text{m} = 0,034\ \text{mm}$$

$$S_{\min} = 1,571 - 0,034 = 1,537$$

Max. actual tooth thickness  $S_{\max} = S_{v \max} - \lambda$

NOTE  $\lambda$  can be calculated from total pitch deviation ( $F_p$ ), total profile deviation ( $F_\alpha$ ) and total helix deviation ( $F_\beta$ ), see 9.2, or  $\lambda$  can be obtained from Table 14.

Total pitch deviation  $F_p = 2,5 \times \sqrt{L} + 6,3$  (formula from Table 7)

where  $L = m \times z \times \frac{\pi}{2} = 1,0 \times 25 \times \frac{\pi}{2} = 39,269\,908\,17$

$$F_p = 2,5 \times \sqrt{39,269\,908\,17} + 6,3 = 21,97 \mu\text{m} = 0,022 \text{ mm}$$

Total profile deviation  $F_\alpha = 1,6 \times \varphi_f + 10$  (formula from Table 8)

where  $\varphi_f = m + 0,012\,5 \times m \times z = 1,0 + 0,012\,5 \times 1,0 \times 25 = 1,312\,50$

Total helix deviation  $F_\beta = 0,8 \cdot \sqrt{b} + 4$  (formula from Table 9)

where  $b$  = length of spline (assume to be one half of the pitch diameter)

$$b = \frac{D}{2} = \frac{25}{2} = 12,50$$

$$F_\beta = 0,8 \times \sqrt{12,50} + 4 = 6,83 \mu\text{m} = 0,007 \text{ mm}$$

Deviation allowance  $\lambda = 0,6 \times \sqrt{F_p^2 + F_\alpha^2 + F_\beta^2}$

$$\lambda = 0,6 \times \sqrt{0,022^2 + 0,012^2 + 0,007^2}$$

$$\lambda = 0,016$$

$$S_{\max} = 1,571 - 0,016 = 1,555$$

Min. effective tooth thickness  $S_{v \min} = S_{\min} + \lambda$

$$S_{v \min} = 1,537 + 0,016 = 1,553$$

Measuring ball or pin diameter  $D_{Re}$  (formulae taken from ISO 4156-3:2005, 8.5.1)

$$\widehat{DE}_e = p_b - (S \times \cos \alpha_D + D_b \times \text{inv} \alpha_D)$$

where  $p_b = m \times \pi \times \cos \alpha_D = 1,0 \times \pi \times \cos(30^\circ) = 2,720\,70$

and  $\text{inv} \alpha_D = \tan \alpha_D - \left( \alpha_D \times \frac{2 \times \pi}{360^\circ} \right) = \tan(30^\circ) - \left( 30^\circ \times \frac{2 \times \pi}{360^\circ} \right) = 0,053\,75$

$$\widehat{DE}_e = 2,720\,70 - (1,571 \times \cos(30^\circ) + 21,650\,64 \times 0,053\,75) = 0,196\,45$$

$$\overline{BA} = \frac{D_b \times \tan \alpha_D}{2} = \frac{21,650 \times 64 \times \tan(30^\circ)}{2} = 6,250\,00$$

$$\overline{BO}_e = \frac{D_b \times \tan \left( \alpha_D + \text{inv} \alpha_D + \frac{\widehat{DE}_e}{D_b} \right)}{2}$$

$$\overline{BO}_e = \frac{21,650\ 64 \times \tan \left[ \left( 30^\circ \times \frac{2 \times \pi}{360^\circ} + 0,053\ 75 + \frac{0,196\ 45}{21,650\ 64} \right) \times \frac{360^\circ}{2 \times \pi} \right]}{2} = 7,192\ 20$$

Calculated  $D_{Re} = 2 \cdot (\overline{BO}_e - \overline{BA}) = 2 \cdot (7,192\ 20 - 6,250\ 00) = 1,884\ 40$

From ISO R40 no. series  $D_{Re} = 1,900$

Max. measurement over balls or pins  $M_{Re\ max}$  (formulae taken from ISO 4156-3:2005, 8.6.1.1)

From above formula  $D_{Re} = 1,900$

$$\text{inv} \alpha_e = \frac{S}{D} + \left( \text{inv} \alpha_D + \frac{D_{Re}}{D_b} - \frac{\pi}{z} \right)$$

$$S = S_{\max} = 1,555$$

$$\text{inv} \alpha_e = \frac{1,555}{25,000} + \left( 0,053\ 75 + \frac{1,900}{21,650\ 64} - \frac{\pi}{25} \right) = 0,078\ 043\ 51$$

$$\alpha_e = 33,609\ 83^\circ$$

For odd numbers of teeth  $M_{Re\ max} = \frac{D_b \cdot \cos \frac{90^\circ}{z}}{\cos \alpha_e} + D_{Re}$

$$M_{Re\ max} = \frac{21,650\ 64 \cdot \cos \left( \frac{90^\circ}{25} \right)}{\cos(33,609\ 83^\circ)} + 1,900 = 27,845$$

Min. measurement over balls or pins  $M_{Re\ min}$

$$S = S_{\min} = 1,537$$

$$\text{inv} \alpha_e = \frac{1,537}{25,000} + \left( 0,053\ 75 + \frac{1,900}{21,650\ 64} - \frac{\pi}{25} \right) = 0,077\ 323\ 51$$

$$\alpha_e = 33,516\ 11^\circ$$

Fillet radius  $\rho_{Fe} = 0,2 \times m$  (formula from Table 2)

$$\rho_{Fe} = 0,2 \times 1,0 = 0,2$$

**A.5 EXT 25z × 1,0m × 30R × 6e - ISO 4156**

NOTE Unless otherwise stated all formulae are provided in Table 1.

Number of teeth	$z = 25$
Module	$m = 1,0$
Pressure angle	$\alpha_D = 30^\circ$
Pitch diameter	$D = m \times z = 1,0 \times 25 = 25,000\ 0$
Base diameter	$D_b = m \times z \times \cos \alpha_D = 1,0 \times 25 \times \cos(30^\circ) = 21,650\ 635\ 09 = 21,650\ 6$
Major diameter	$D_{ee\ max} = m \cdot (z + 1) + \frac{es_v}{\tan \alpha_D}$

From Clause 10, adjustment is made to the major, form and minor diameters for fundamental deviation e.

So, from Table 5  $es_v = -0,040$

$$D_{ee\ max} = 1,0 \cdot (25 + 1) + \left( \frac{-0,040}{\tan(30^\circ)} \right) = 25,930\ 7$$

$$D_{ee} = 25,93\ h11\ (0/-0,130)$$

$$D_{Fe\ max} = 2 \times \sqrt{(0,5 \times D_b)^2 + \left( 0,5 \times D \times \sin \alpha_D - \frac{h_s - \frac{0,5 \times es_v}{\tan \alpha_D}}{\sin \alpha_D} \right)^2}$$

From Table 2  $h_s = 0,6 \cdot m = 0,6 \cdot 1,0 = 0,6$

From Table 5  $es_v = -0,040$

$$D_{Fe\ max} = 2 \times \sqrt{(0,5 \times 21,650\ 64)^2 + \left( 0,5 \times 25,0 \times \sin(30^\circ) - \frac{0,6 - \frac{0,5 \times (-0,040)}{\tan(30^\circ)}}{\sin(30^\circ)} \right)^2}$$

$$D_{Fe\ max} = 23,83$$

Maximum minor diameter (*fillet* root) — not tabulated but necessary for calculating minimum minor diameter.

$$D_{ie\ max} = m \times (z - 1,8) + \frac{es_v}{\tan \alpha_D} = 1,0 \times (25 - 1,8) + (-0,069) = 23,13$$

$$\text{Minimum minor diameter } D_{ie\ min} = D_{ie\ max} - \frac{(T + \lambda)}{\tan \alpha_D}$$

From 9.1 class 7  $(T + \lambda) = 40 \cdot i_d + 160 \cdot i_E$

$$i_d = 0,45 \cdot \sqrt[3]{D} + 0,001 \cdot D = 0,45 \cdot \sqrt[3]{25,0} + 0,001 \cdot 25,0 = 1,340 8$$

$$i_E = 0,45 \cdot \sqrt[3]{E} + 0,001 \cdot E$$

$$E = 0,5 \cdot \pi \cdot m = 0,5 \cdot \pi \cdot 1,0 = 1,571$$

$$i_E = 0,45 \cdot \sqrt[3]{1,571} + 0,001 \cdot 1,571 = 0,524 7$$

$$T + \lambda = 40 \cdot 1,340 8 + 160 \cdot 0,524 7 = 137,584 \mu\text{m} = 0,138 \text{ mm}$$

$$D_{ie \text{ min}} = 23,13 - \frac{0,138}{\tan(30^\circ)} = 22,89$$

Max. effective tooth thickness  $S_{v \text{ max}} = S + es_v$

$$S = 0,5 \times \pi \times m = 0,5 \times \pi \times 1,0 = 1,571$$

$$S_{v \text{ max}} = 1,571 + (-0,040) = 1,531$$

Min. actual tooth thickness  $S_{\text{min}} = S_{v \text{ max}} - (T + \lambda)$

From 9.1 class 6  $(T + \lambda) = 25 \cdot i_d + 100 i_E$

From above formula  $i_d = 1,340 8$  et  $i_E = 0,524 7$

$$T + \lambda = 25 \cdot 1,340 8 + 100 \cdot 0,524 7 = 85,990 \mu\text{m} = 0,086 \text{ mm}$$

$$S_{\text{min}} = 1,531 - 0,086 = 1,445$$

Max. actual tooth thickness  $S_{\text{max}} = S_{v \text{ max}} - \lambda$

NOTE  $\lambda$  can be calculated from total pitch deviation ( $F_p$ ) total profile deviation ( $F_\alpha$ ) and total helix deviation ( $F_\beta$ ), see 9.2, or  $\lambda$  can be obtained from Table 14.

Total pitch deviation  $F_p = 5 \times \sqrt{L} + 12,5$  (formula from Table 7)

where  $L = m \times z \times \frac{\pi}{2} = 1,0 \times 25 \times \frac{\pi}{2} = 39,269 908 17$

$$F_p = 5 \times \sqrt{39,269 908 17} + 12,5 = 43,83 \mu\text{m} = 0,044 \text{ mm}$$

Total profile deviation  $F_\alpha = 4 \times \varphi_f + 25$  (formula from Table 8)

where  $\varphi_f = m + 0,012 5 \times m \times z = 1,0 + 0,012 5 \times 1,0 \times 25 = 1,312 50$

$$F_\alpha = 4 \times 1,312 50 + 25 = 30,25 \mu\text{m} = 0,030 \text{ mm}$$

Total helix deviation  $F_\beta = 1,25 \times \sqrt{b} + 6,3$  (formula from Table 9)

where  $b$  = length of spline (assumed to be one half of the pitch diameter)

$$b = \frac{D}{2} = \frac{25}{2} = 12,50$$

$$F_{\beta} = 1,25 \times \sqrt{12,50} + 6,3 = 10,72 \mu\text{m} = 0,011 \text{ mm}$$

$$\text{Deviation allowance } \lambda = 0,6 \cdot \sqrt{F_p^2 + F_{\alpha}^2 + F_{\beta}^2}$$

$$\lambda = 0,6 \times \sqrt{0,044^2 + 0,030^2 + 0,011^2}$$

$$\lambda = 0,033$$

$$S_{\max} = 1,531 - 0,033 = 1,498$$

$$\text{Min. effective tooth thickness } S_{V \min} = S_{\min} + \lambda$$

$$S_{V \min} = 1,445 + 0,033 = 1,478$$

Measuring ball or pin diameter  $D_{Re}$  (formulae taken from ISO 4156-3:2005, 8.5.1)

$$\widehat{DE}_e = p_b - (S \times \cos \alpha_D + D_b \times \text{inv} \alpha_D)$$

$$\text{where } p_b = m \times \pi \times \cos \alpha_D = 1,0 \times \pi \times \cos(30^\circ) = 2,720 70$$

$$\text{and } \text{inv} \alpha_D = \tan \alpha_D - \left( \alpha_D \times \frac{2 \times \pi}{360^\circ} \right) = \tan(30^\circ) - \left( 30^\circ \times \frac{2 \cdot \pi}{360^\circ} \right) = 0,053 75$$

$$\widehat{DE}_e = 2,720 70 - (1,571 \times \cos(30^\circ) + 21,650 64 \times 0,053 75) = 0,196 45$$

$$\overline{BA} = \frac{D_b \times \tan \alpha_D}{2} = \frac{21,650 64 \times \tan(30^\circ)}{2} = 6,250 00$$

$$\overline{BO}_e = \frac{D_b \times \tan \left( \alpha_D + \text{inv} \alpha_D + \frac{\widehat{DE}_e}{D_b} \right)}{2}$$

$$\overline{BO}_e = \frac{21,650 64 \times \tan \left[ \left( 30^\circ \times \frac{2 \times \pi}{360^\circ} + 0,053 75 + \frac{0,196 45}{21,650 64} \right) \times \frac{360^\circ}{2 \times \pi} \right]}{2} = 7,192 20$$

$$\text{Calculated } D_{Re} = 2 \times (\overline{BO}_e - \overline{BA}) = 2 \times (7,192 20 - 6,250 00) = 1,884 40$$

$$\text{From ISO R40 no. series } D_{Re} = 1,900$$

Maximum measurement over balls or pins  $M_{Re \max}$  (formulae taken from ISO 4156-3:2005, 8.6.1.1)

$$\text{From above formula } D_{Re} = 1,900$$

$$\operatorname{inv} \alpha_e = \frac{S}{D} + \left( \operatorname{inv} \alpha_D + \frac{D_{\text{Re}}}{D_b} - \frac{\pi}{z} \right)$$

$$S = S_{\text{max}} = 1,498$$

$$\operatorname{inv} \alpha_e = \frac{1,498}{25,000} + \left( 0,053\,75 + \frac{1,900}{21,650\,64} - \frac{\pi}{25} \right) = 0,075\,763\,51$$

$$\alpha_e = 33,310\,74^\circ$$

For odd numbers of teeth  $M_{\text{Re max}} = \frac{D_b \cdot \cos \frac{90^\circ}{z}}{\cos \alpha_e} + D_{\text{Re}}$

$$M_{\text{Re max}} = \frac{21,650\,64 \cdot \cos \left( \frac{90^\circ}{25} \right)}{\cos (33,310\,74^\circ)} + 1,900 = 27,756$$

Min. measurement over balls or pins  $M_{\text{Re min}}$

$$S = S_{\text{min}} = 1,445$$

$$\operatorname{inv} \alpha_e = \frac{1,445}{25,000} + \left( 0,053\,75 + \frac{1,900}{21,650\,64} - \frac{\pi}{25} \right) = 0,073\,643\,51$$

$$\alpha_e = 33,026\,41^\circ$$

$$M_{\text{Re min}} = \frac{21,650\,64 \times \cos \left( \frac{90^\circ}{25} \right)}{\cos (33,026\,41^\circ)} + 1,900 = 27,672$$

Fillet radius  $\rho_{\text{Fe}} = 0,4 \times m$  (formula from Table 2)

$$\rho_{\text{Fe}} = 0,4 \times 1,0 = 0,4$$

## A.6 EXT 25z × 1,0m × 30P × 5js - ISO 4156

NOTE Unless otherwise stated all formulae are provided in Table 1.

Number of teeth  $z = 25$

Module  $m = 1,0$

Pressure angle  $\alpha_D = 30^\circ$

Pitch diameter  $D = m \cdot z = 1,0 \cdot 25 = 25,000\,0$

Base diameter  $D_b = m \cdot z \cdot \cos \alpha_D = 1,0 \cdot 25 \cdot \cos(30^\circ) = 21,650\,635\,09 = 21,650\,6$

Major diameter 
$$D_{ee \max} = m \times (z + 1) + \frac{es_v}{\tan \alpha_D}$$

From Clause 10, no adjustment is applied to the major diameter, but adjustment is applied to the form and minor diameters for fundamental deviation js.

So, 
$$\frac{es_v}{\tan \alpha_D} = 0$$

$$D_{ee \max} = 1,0 \times (25 + 1) + 0 = 26,00$$

$$D_{ee} = 26,00 \text{ h11 } (0/-0,130)$$

Form diameter 
$$D_{Fe \max} = 2 \times \sqrt{(0,5 \times D_b)^2 + \left( 0,5 \times D \times \sin \alpha_D - \frac{h_s - \frac{0,5 \times es_v}{\tan \alpha_D}}{\sin \alpha_D} \right)^2}$$

From Table 2 
$$h_s = 0,6 \cdot m = 0,6 \cdot 1,0 = 0,6$$

From Table 5, Footnote a 
$$es_v = \frac{T + \lambda}{2}$$

From 9.1 class 5 
$$(T + \lambda) = 16 \cdot i_d + 64 \cdot i_E$$

$$i_d = 0,45 \cdot \sqrt[3]{D} + 0,001 \cdot D = 0,45 \cdot \sqrt[3]{25,0} + 0,001 \cdot 25,0 = 1,340 \text{ 8}$$

$$i_E = 0,45 \cdot \sqrt[3]{E} + 0,001 \cdot E$$

$$E = 0,5 \cdot \pi \cdot m = 0,5 \cdot \pi \cdot 1,0 = 1,571$$

$$i_E = 0,45 \cdot \sqrt[3]{1,571} + 0,001 \cdot 1,571 = 0,524 \text{ 7}$$

$$T + \lambda = 16 \cdot 1,340 \text{ 8} + 64 \cdot 0,524 \text{ 7} = 55,03 \text{ }\mu\text{m} = 0,055 \text{ mm}$$

$$es_v = \frac{0,055}{2} = 0,028$$

$$D_{Fe \max} = 2 \times \sqrt{(0,5 \times 21,650 \text{ 64})^2 + \left( 0,5 \times 25,0 \times \sin(30^\circ) - \frac{0,6 - \frac{0,5 \times 0,028}{\tan(30^\circ)}}{\sin(30^\circ)} \right)^2}$$

$$D_{Fe \max} = 23,93$$

Maximum minor diameter (*flat root*) — not tabulated but necessary for calculating minimum minor diameter.

$$D_{ie \max} = m \times (z - 1,5) + \frac{es_v}{\tan \alpha_D} = 1,0 \times (25 - 1,5) + \frac{0,028}{\tan(30^\circ)} = 23,55$$

Min. minor diameter  $D_{ie \min} = D_{ie \max} - \frac{(T + \lambda)}{\tan \alpha_D}$

From 9.1 class 7  $(T + \lambda) = 40 i_d + 160 i_E$

From above formula  $i_d = 1,3408$  and  $i_E = 0,5247$

$$T + \lambda = 40 \cdot 1,3408 + 160 \cdot 0,5247 = 137,584 \mu\text{m} = 0,138 \text{ mm}$$

$$D_{ie \min} = 23,55 - \frac{0,138}{\tan(30^\circ)} = 23,31$$

Max. effective tooth thickness  $S_{v \max} = S + e_{s_v}$

$$S = 0,5 \times \pi \times m = 0,5 \times \pi \times 1,0 = 1,571$$

$$S_{v \max} = 1,571 + 0,028 = 1,599$$

Minimum actual tooth thickness  $S_{\min} = S_{v \max} - (T + \lambda)$

From above formula class 5  $(T + \lambda) = 0,055$

$$S_{\min} = 1,599 - 0,055 = 1,544$$

Max. actual tooth thickness  $S_{\max} = S_{v \max} - \lambda$

NOTE  $\lambda$  can be calculated from total pitch deviation ( $F_p$ ) total profile deviation ( $F_\alpha$ ) and total helix deviation ( $F_\beta$ ), see 9.2, or  $\lambda$  can be obtained from Table 14.

Total pitch deviation  $F_p = 3,55 \times \sqrt{L} + 9$  (formula from Table 7)

where  $L = m \times z \times \frac{\pi}{2} = 1,0 \times 25 \times \frac{\pi}{2} = 39,269\ 908\ 17$

$$F_p = 3,55 \times \sqrt{39,269\ 908\ 17} + 9 = 31,25 \mu\text{m} = 0,031 \text{ mm}$$

Total profile deviation  $F_\alpha = 2,5 \times \varphi_f + 16$  (formula from Table 8)

where  $\varphi_f = m + 0,012\ 5 \times m \times z = 1,0 + 0,012\ 5 \times 1,0 \cdot 25 = 1,312\ 50$

$$F_\alpha = 2,5 \times 1,312\ 50 + 16 = 19,28 \mu\text{m} = 0,019 \text{ mm}$$

Total helix deviation  $F_\beta = \sqrt{b} + 5$  (formula from Table 9)

where  $b$  = length of spline (assume to be one half of the pitch diameter)

$$b = \frac{D}{2} = \frac{25}{2} = 12,50$$

$$F_\beta = \sqrt{12,50} + 5 = 8,54 \mu\text{m} = 0,009 \text{ mm}$$

Deviation allowance  $\lambda = 0,6 \cdot \sqrt{F_p^2 + F_\alpha^2 + F_\beta^2}$

$$\lambda = 0,6 \times \sqrt{0,031^2 + 0,019^2 + 0,009^2}$$

$$\lambda = 0,022$$

$$S_{\max} = 1,599 - 0,022 = 1,577$$

Min. effective tooth thickness  $S_{v \min} = S_{\min} + \lambda$

$$S_{v \min} = 1,544 + 0,022 = 1,566$$

Measuring ball or pin diameter  $D_{re}$  (formulae taken from ISO 4156-3:2005, 8.5.1)

$$\widehat{DE}_e = p_b - (S \times \cos \alpha_D + D_b \times \text{inv} \alpha_D)$$

where  $p_b = m \times \pi \times \cos \alpha_D = 1,0 \times \pi \times \cos(30^\circ) = 2,720\ 70$

and  $\text{inv} \alpha_D = \tan \alpha_D - \left( \alpha_D \times \frac{2 \times \pi}{360^\circ} \right) = \tan(30^\circ) - \left( 30^\circ \times \frac{2 \times \pi}{360^\circ} \right) = 0,053\ 75$

$$\widehat{DE}_e = 2,720\ 70 - (1,571 \times \cos(30^\circ) + 21,650\ 64 \cdot 0,053\ 75) = 0,196\ 45$$

$$\overline{BA} = \frac{D_b \times \tan \alpha_D}{2} = \frac{21,650\ 64 \times \tan(30^\circ)}{2} = 6,250\ 00$$

$$\overline{BO}_e = \frac{D_b \times \tan \left( \alpha_D + \text{inv} \alpha_D + \frac{\widehat{DE}_e}{D_b} \right)}{2}$$

$$\overline{BO}_e = \frac{21,650\ 64 \times \tan \left[ \left( 30^\circ \times \frac{2 \times \pi}{360^\circ} + 0,053\ 75 + \frac{0,196\ 45}{21,650\ 64} \right) \times \frac{360^\circ}{2 \times \pi} \right]}{2} = 7,192\ 20$$

Calculated  $D_{Re} = 2 \times (\overline{BO}_e - \overline{BA}) = 2 \times (7,192\ 20 - 6,250\ 00) = 1,884\ 40$

From ISO R40 no. series  $D_{Re} = 1,900$

Maximum measurement over balls or pins  $M_{Re \max}$  (formulae taken from ISO 4156-3:2005, 8.6.1.1)

From above formula  $D_{Re} = 1,900$

$$\text{inv} \alpha_e = \frac{S}{D} + \left( \text{inv} \alpha_D + \frac{D_{Re}}{D_b} - \frac{\pi}{z} \right)$$

$$S = S_{\max} = 1,577$$

$$\operatorname{inv} \alpha_e = \frac{1,577}{25,000} + \left( 0,053\,75 + \frac{1,900}{21,650\,64} - \frac{\pi}{25} \right) = 0,078\,923\,51$$

$$\alpha_e = 33,723\,47^\circ$$

For odd numbers of teeth  $M_{\text{Re max}} = \frac{D_b \cdot \cos \frac{90^\circ}{z}}{\cos \alpha_e} + D_{\text{Re}}$

$$M_{\text{Re max}} = \frac{21,650\,64 \cdot \cos \left( \frac{90^\circ}{25} \right)}{\cos(33,723\,47^\circ)} + 1,900 = 27,880$$

Minimum measurement over balls or pins  $M_{\text{Re min}}$

$$S = S_{\text{min}} = 1,544$$

$$\operatorname{inv} \alpha_e = \frac{1,544}{25,000} + \left( 0,053\,75 + \frac{1,900}{21,650\,64} - \frac{\pi}{25} \right) = 0,077\,603\,51$$

$$\alpha_e = 33,552\,63^\circ$$

$$M_{\text{Re min}} = \frac{21,650\,64 \cdot \cos \left( \frac{90^\circ}{25} \right)}{\cos(33,552\,63^\circ)} + 1,900 = 27,828$$

Fillet radius  $\rho_{\text{Fe}} = 0,2 \times m$  (formula from Table 2)

$$\rho_{\text{Fe}} = 0,2 \times 1,0 = 0,2$$

## Bibliography

- [1] ISO 3, *Preferred numbers — Series of preferred numbers*

